

OPUS

2023 USER MANUAL

AIR **OPUS**®

BUILT BY OPUS CAMPER IN CALIFORNIA
925.215.7315 | WWW.OPUSCAMPER.US

OPUS®
OFF-ROAD

CONTENTS

2. Contents
3. Welcome Message
4. My OPUS® Camper
5. Vehicle Identification Number (VIN)
6. Specifications
8. Dimensions
10. Hitching & Towing
11. Wheels & Brakes
12. Control Panel
13. OPUS® Quick Set-Up Guide
14. Setting Up your OPUS® Camper
18. Packing Down your OPUS® Camper
20. AIR Tent Design
22. About your KITCHEN
23. About your FRIDGE
24. Gas System
26. Propane Heater - TRUMA
27. Shower Tent Set-up
28. Water System
30. Electrical System
32. Options & Accessories
33. Additional Bed Set-Up Guide
34. AIR Canopy Set-up
36. AIR Annex Set-up
38. Care & Maintenance
46. Inside Your OP2
47. OP2 Features
48. Warranty
50. Troubleshooting
51. Resources

Online Resources:

www.opuscamper.us
www.opusowners.com
www.opuscamper.us/2-sleeper/

Warranty Activation:

www.opuscamper.us/warranty/



OP2 Website:

Find links to your user manual, photos, videos and accessories.



Warranty Activation:

Follow this code to activate your OPUS warranty



OPUS Owners Group:

Get tips and tricks, share stories and ask questions with hundreds of other OPUS owners online.



Shop OPUS Accessories:

Shop multiple options for cover, power, shade, security and gear to take you further off-grid.

WELCOME!

We're so pleased that you have chosen an OPUS Camper Trailer and we welcome you to the adventure lifestyle. Our goal is to help every customer push boundaries and explore further, to find and to foster that love for the great outdoors, and with the help of their Off-Road trailer as a base camp we hope to help our customers find their inner adventurer.

We are committed to providing the highest level of customer service and so we've put together this user manual to help guide you through the process of learning about your new OPUS trailer. We strongly suggest that you review this manual in its entirety before using your new Opus Camper. Your dealership should be able to answer any questions you have and we are very happy to assist with any further questions that arise. Getting to know your new camper well and following the guidelines, instructions and warnings laid out in this manual will help to ensure that you get the most out of your camper and with considerate treatment and care it will be your companion for your camping adventures for years to come. We recommend that you keep this Owner's Manual with your camper as a reference guide for when you are out on your adventures. If you need a digital copy of this manual please contact us at OPUS Camper USA and we would be happy to provide you with one.

Here at OPUS we demand a high standard of build in our trailers; to ensure the highest quality our team follow a strict build and inspection process before delivery. Your dealership will also run their own inspection on the camper before it reaches you. We encourage you to take the time with your dealer when you collect your trailer to familiarize yourself with the camper and understand the tests that they have run to ensure that everything is working as it should.

If you suspect your OPUS Camper is not working correctly, please contact your dealer to arrange an appointment. If you are traveling & experience a problem, please first contact your dealership before any repairs are carried out by a local independent service department to ensure that you will still be covered under warranty. Retain all invoices and documentation to allow for proper reimbursement through your dealer. For appliances, please refer to the appliance manual for support and warranty assistance.

The OP2 trailer is designed for recreational use only. We would encourage you to familiarize yourself with the warranty for your trailer to ensure that your use falls in line with the intended usage covered under warranty. Usage outside of these terms could reduce or void your warranty. You will find the OPUS warranty information in the back of this user manual. Please be sure to follow up with your dealership to make sure they have completed and returned the required warranty registration form to activate your warranty.

Please note that there may be differences in the products or design shown or described in this manual from your camper. This manual was correct at the time of publication however we promote an on-going improvement process within our builds and we reserve the right to change the construction or design at any time without the obligation to make these changes on previous manufactured trailers. If significant changes are made to the design or build of our models we will take the appropriate steps to update this manual accordingly for the benefit of our customers. Please contact the OPUS Camper USA team for a digital copy for our most up to date user manual.

Should you have any questions about your OP2 trailer, no matter how small we are here to help. You can reach us at info@opuscamper.us or call us on 925.215.7215.

We hope you enjoy your OPUS Camper and we wish you many happy memories

Sincerely,

The OPUS Camper Team

Follow us on: Instagram

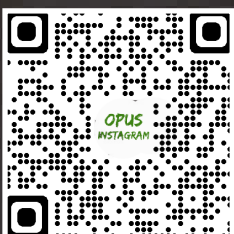

Follow us on: Facebook

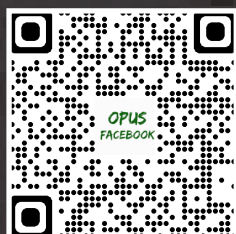

MY OPUS CAMPER

OWNER'S NAME

ADDRESS

MODEL

VIN

This information can be found on the exterior of your OP2

DOB (BUILD DATE)

DRY WEIGHT

CARGO CAPACITY

TIRE SIZE

COLD TIRE PRESSURE

This information can be found on the tire sticker of your OP2

DEALERSHIP OF PURCHASE



WARRANTY ACTIVATION

Follow this code to activate your OPUS warranty.

For specific details regarding your warranty see pages 47 & 48 of this manual, or visit our website at www.opuscamper.us

VIN: VEHICLE IDENTIFICATION

Every OPUS® has a Vehicle Identification Number (VIN).

The VIN Plate can be found on the exterior of your OPUS® to the left of the door.

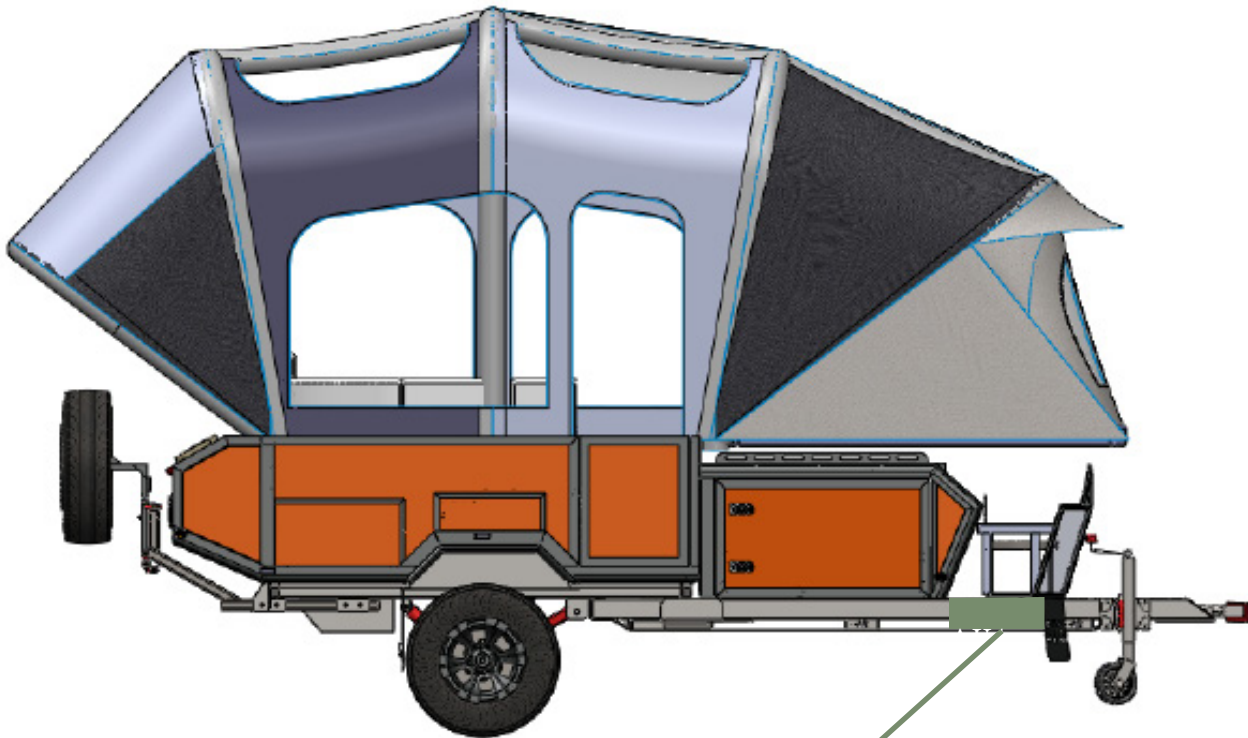

MANUFACTURED BY:		DATE:	
GVWR	KG(LB)	
GAWR ALL	KG(LB) PER AXLE WITH	TIRE RIM
AT	KPA(PSI) COLD SINGLE	
THIS VEHICLE CONFORMS TO ALL APPLICABLE US FEDERAL MOTOR VEHICLE SAFETY STANDARDS IN EFFECT ON THE DATE OF MANUFACTURE SHOWN ABOVE.			
VIN:		TYPE: TRAILER	MODEL:
			FD-304

We recommend making a note of your VIN in the template as shown. This will be required by insurance companies.

OP2 SPECIFICATION

BUILD

Color	OPUS Orange, OPUS Blue, Metallic Grey, Matte Black, ARMY Green
Body Work	Baked Enamel Finish
Box Material	Main body aluminum tube & composite panel exterior; fully hot-dip galvanized chassis with draw-bar
Dimensions (Lid Closed)	18'2" (including spare wheel) x 6'7" x 4'9"
Dimensions (Lid Open)	21'4" x 6'10" x 11'6"
Ground Clearance	15'7"
Ride Height	3'2"
Chassis	8'2" x 6'2" x 2'4"
Drawbar	8'6" x 4'7" x 4"
Bed Size	6'2" x 5'5" x 4"
Dry Weight	3244 lbs (tent included)
Tongue Weight	355lbs
GVWR	4400 lbs (WITH the cargo rack-mounted)
Load Capacity	1100
Cargo Capacity	500

EXTERIOR FEATURES

Coupling	Lock'n'roll articulating hitch
Suspension	Independent Coil Spring Suspension with Dual Shock Absorbers
Kitchen	Stainless steel slide out kitchen with 4 burner stove & sink with electric tap and spice rack
Water System	1 x 12v electric water pump
Water Tank	1 x 20gl (rear tank) 1x 11gl (front tank) stainless steel tank
Water Tank Guard	Checker plate protection
Frige Tray	35" x 21" x 18"
Stabilizer legs	4 x drop-down, lockable and adjustable
Tongue Jack Wheel	Adjustable height
Jerry Can Holder	2 x 5gl
Gas Bottle Holder	20lbs adjustable holder
Stone Guard	Front surface coated with anti-chip deadener
Wheels	15" Stud alloy rim 235/75R15
Spare Wheel	15" Stud alloy rim 235/75R15
Brake System	12v Electric Drum Brakes with additional E-brake to assist with un-hitching and trailer brake-away system.
Lights	LED dimmable foot-well lights and individually switched LED ceiling strip lights
Cargo Rack	Fold-over cargo rack with 500lbs load capacity

INTERIOR FEATURES

Seating	Sectional Leatherette Cushions
Table	Adjustable height fold-away table
Storage	Under-bench storage compartments
Bathroom	Optional porta potti cassette toilet
Heating (optional)	16,000 BTU TRUMA propane furnace
Sleeping	1 RV Queen Bed, seating area converts to second bed.

ELECTRICAL

Batteries	2 x 100ah 12v AGM Batteries
Shore Power	30 Amp shore power connection with 2 x 120v outlets
Solar	Optional solar port for trickle-charging your battery
Stereo	12v Stereo with interior speakers, Bluetooth & direct connection, CD and Radio

TENT

Material	12oz / 420g fine weave Polycotton
AIR Beams	Dual-layer protected AIR Beams with isolated valves
Tropical Roof	Waterproof and UV protected Tropical roof included
Annex (optional)	Fully enclosed AIR inflatable Annex
Sun Awning (optional)	Zip-attach sun awning with extendable poles
Inflatable Sun Awning	Zip-attach sun awning with AIR beams and main tent connectivity



OP2 DIMENSIONS

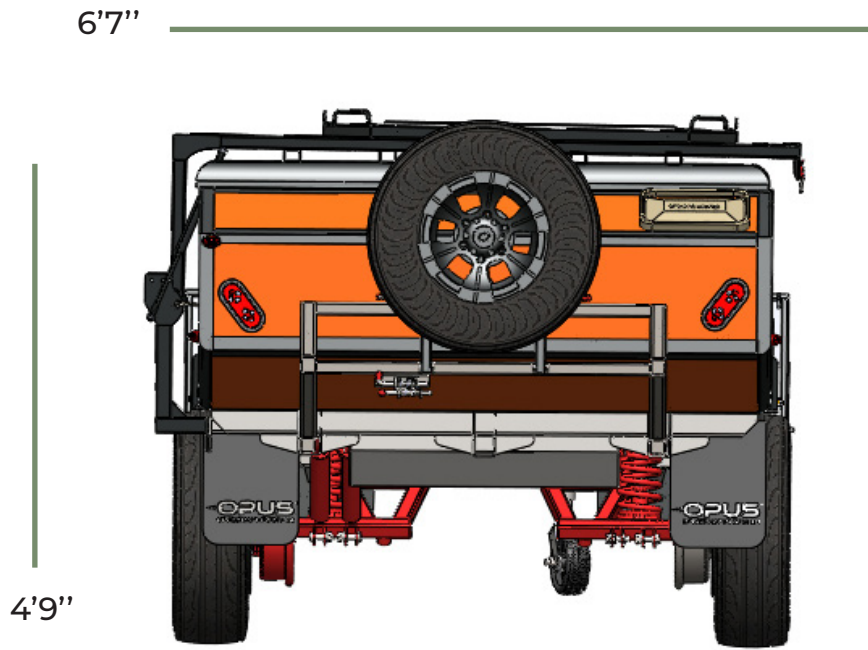

SHOWER DIMENSIONS



18'2" (including spare wheel)



21'4" (with tent inflated)



ABOUT YOUR HITCH

LOCK'N'ROLL HITCH

The OP2 comes as standard with a Lock'n'Roll articulating hitch. The hitch allows for pivoting on 3 axis and provides an overall smooth towing experience. Ensure the locking pin is fully inserted and secured in place before towing. When hitching the OPUS® to your towing vehicle you must ensure that someone is close to the handbrake in order to maintain control of the trailer, particularly when unhitching on uneven ground or a slope. The Lock'n'roll hitch is a two-part hitch with a vehicle-side and a driver side part.

- The vehicle side fits in a 2" hitch receiver and should be locked in place with an appropriate hitch receiver lock.
- The trailer side is already installed on your OP2.
- To connect the two parts, the trailer side pin arms should be placed in the receiving section on the vehicle side part.
- The hook arms then fit over the trailer-side pin arms and a securing pin is fitted through the holes in the hook arms and the hole in the main receiving section on the vehicle side part.
- This will hold the trailer side pin arms in place.
- Use a locking pin on the securing pin to fully lock the coupling in place.

TRAILER-SIDE HITCH PART

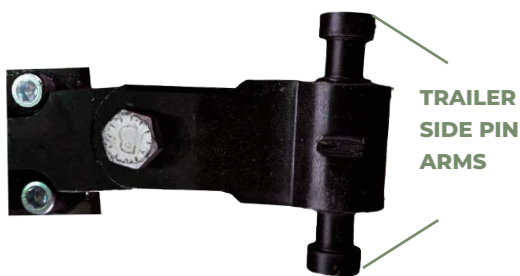

VEHICLE-SIDE HITCH PART



CORRECT HITCH COUPLING POSITION FOR TRAVEL

Hook arms fit over trailer-side pin arms. NOTE securing pin through holes in hook arms and locking pin to hold it in place

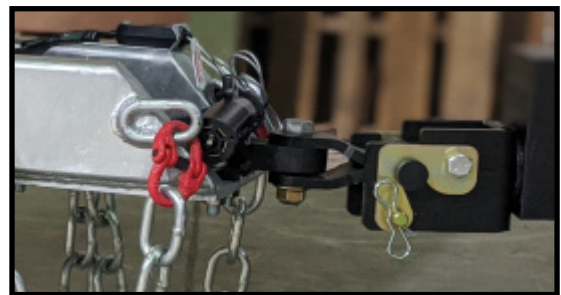

WATCH THE VIDEO!

Watch this HOW-TO video on everything you need to know about towing your OP2. Watch detailed instructions on using your Lock'n'Roll hitch, brakes, safety chains, tongue jack and brake adjustments.

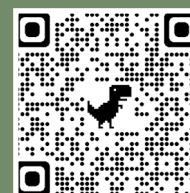

WHEELS, BRAKES & TIRES

WHEELS & TIRES

Torque all wheel bolts to 100ft lbs. When tightening wheel nut lugs, please tighten bolts in a star-pattern order as indicated in the diagram to the right.



ABOUT YOUR ELECTRICAL PLUG

7 PIN The OPUS® is fitted with a 7-pin flat plug that connects all the exterior trailer running/brake/turn lights and the electric brakes to the towing vehicle. You will require a 7-pin connection on your tow-vehicle as well as an in-car electric brake controller installed in your tow vehicle to operate them.



INSTALLING YOUR SAFETY CHAINS

The OPUS® is fitted with 2 safety chains on the tongue. One end of the chain is fitted to the OPUS® chassis and the other end has an attachment clip which should be attached securely to your tow vehicle bumper or receiver.

- Ensure the clips on the hooks are in place to fully secure the hooks.
- Do not attach the hooks to the hitch itself.
- Ensure that you have enough slack in the chains to turn your vehicle adequately.
- Should you require less slack, the chains can be twisted or crossed below the tongue before connecting to your vehicle to ensure the chains do not drag on the ground.



ABOUT YOUR BRAKES

The OPUS® is fitted with electric trailer brakes. You need an electric brake controller fitted to your car in order to tow the OPUS® and operate the electric breaks safely. Failure to tow with a brake controller in your vehicle is both dangerous and illegal. You can tell if your brakes are working properly by connecting the 7-pin plug, starting the engine of the tow vehicle and then getting someone to listen to the brake hub whilst another person applies the brakes in the tow vehicle. If they are working correctly you will here a low humming sound as the brakes are applied.

BRAKE MAINTENANCE

As part of the annual service check you should have completed by an accredited industry service agent, the brakes will be checked and maintained.

TOWING

The driver of the tow vehicle must ensure that their Driving License is valid for towing the OPUS® Camper. It is highly recommended, particularly if you are not experienced in towing that you adhere to any applicable laws for the state in which you are driving. Many guides are available from leading associations and should be studied before you embark. Trailer towing laws are different in each state. Please be aware If you are traveling across multiple states that you could suddenly be breaking tow laws if you're not careful. States differ on their rules about multiple trailers. If you're hauling a camper and a Jet Ski behind it, you'd be OK in South Carolina, but breaking the law once you cross the Georgia state line. No matter where you are in the U.S., the following features are recommended safety equipment for trailer towing:

- * Lights: Your trailer lights must be maintained in working order for basic road safety.
- * License plate light: Make sure to clearly display your license plate
- * Reflectors: These are an invaluable precaution to keep your large trailer visible.
- * Flares: Keep these at hand to clear off a section of the road after an accident.
- * Tie-downs: If you are loading anything on a trailer that could possibly fall off, you'll need tie-downs to secure it at multiple angles.

CONTROL PANEL

CONTROL PANEL FEATURES

1. Main Power Key Switch
2. Air Inflation Button
3. Voltage/Amp Meter
4. Battery Level Indicator
5. Front Tank
6. 12V Socket
7. Rear Tank
8. Water Pump
9. Lights
10. Indoor Plugs
11. Fridge

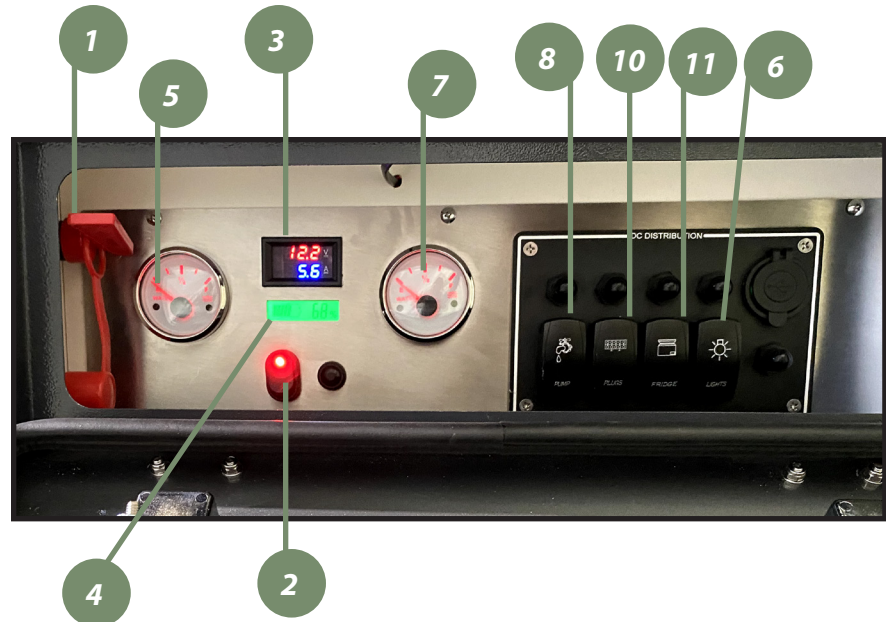

Each switch on the control panel has its own breaker located directly above the switch.

CONTROL PANEL QUICK TIPS

- The Volt Meter – Measures the current battery voltage output. Most appliances will require at least 12.2v from the batteries otherwise they will not work.
- Amp Meter – This shows how many Amps you are currently using. The OPUS® has 2 x 100ah AGM batteries. This gives you 100 usable amps for off-site power.
- Battery Indicator – This shows the total capacity remaining in your batteries. If you are showing 50% on your battery meter then your batteries will not put out the 12.2v required for most accessories to operate.
- Ensuring you keep a close eye on all 3 gauges will help to make sure you are fully informed on the current performance of your 12v battery powered electrical system.

VOLTAGE METER

- The Upper Number shows what Voltage (power level) the batteries are currently reading. It is the strength of the current flowing from the batteries.
- If this number were to drop beneath 12.0v with no load (i.e. no accessories running on the OPUS®) then it is highly likely all the appliances inside your camper would stop working as the batteries are not able to put out enough voltage to keep these appliances running.
- Do not take a reading when an appliance, such as a fridge, is running. It will give a false reading. Voltage may appear below 12.0 if the batteries are under load (fridge is actively running).
- The lower number shows the quantity of energy you are currently utilizing from the batteries.
- If you imagine a water tank holding 100gallons and you drain 4 gallons an hour (gallons would represent amps), then you can tell how quickly under current usage conditions your batteries will be fully drained.
- Remember your appliances all cycle at different rates so this number becomes very important for estimating battery life.

QUICK SET-UP GUIDE

STEP 1

Lower the tongue jack. Release the spare wheel carrier to the swing down position as shown.



STEP 2

Unlatch and raise the cargo rack to the set-up position. Unlatch the bed lid & open.



STEP 3

Turn on the AIR compressor. **DON'T FORGET** to make sure your quick release valves on the AIR tent are closed and that the AIR compressor hose is in the AIR tent inlet valve!



STEP 4

While the tent is inflating, fold down your corner steadies & stabilize your trailer. Pull the tent over the bed end corners & fix the bed support arms in place.



STEP 5

Slide open your kitchen & fridge. Connect your quick connects and fold down your kitchen support leg. Set up your sink drain and waste water carrier.



STEP 6

DON'T FORGET to cap your AIR inlet valve on inflated! Set up your cushions and table inside. You can then set up your additional accessories such as solar and awnings.



We strongly recommend you review the OPUS® Off-Road User Manual thoroughly before setting up your OPUS® Off-Road Camper for the first time. For information about setting up your kitchen, shower and other accessories, please see the corresponding page in this manual.

OP2 SET-UP

STEP 1

PREPARE TO DEPLOY YOUR CAMPER

- Once you have positioned your OPUS® in the desired location, engage the handbrake.
- Raise or lower the tongue jack wheel to level your OPUS® length ways.
- Remove all items from the Cargo Rack.
- Un-clip the securing latches on the passengers side.
- On the drivers side remove locking pins and unfold the Cargo Rack and secure the locking pins back in place.

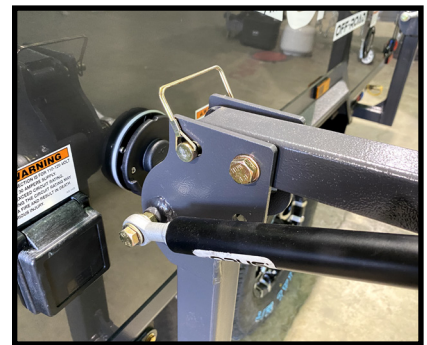
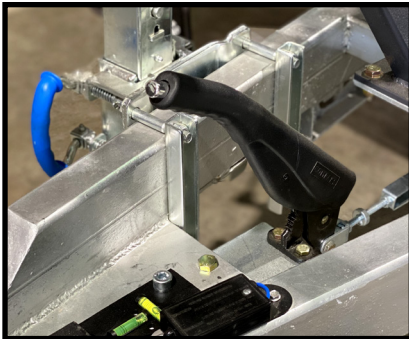

STEP 2

SWING DOWN SPARE TIRE

- Un-clip the spare wheel carrier using the blue spring levers.
- Carefully swing down the spare tire.
- Take care to support the weight of the spare wheel carrier so that it does not swing free and fall whilst out of control.

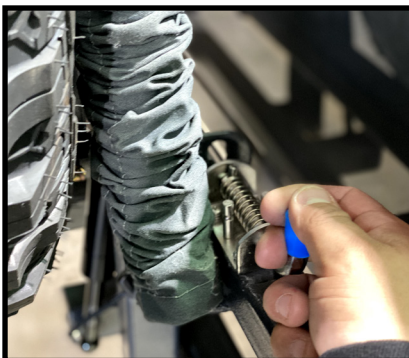

STEP 3

OPEN THE BED LID

- Open the bed lid through 180°. Gas struts are fitted to support the weight of the lid at this stage.
- Secure the lid to the stone guard frame with the latch and secure with the retaining pin.
- At this stage walk around the OPUS® and inspect the tent to ensure that the canvas is properly located within the aluminum channels and that no part of the tent is caught or snagged.
- Fit each corner of the canvas over the corner of each bed tray. The seam on the canvas should line up with each corner



STEP 4

INFLATE YOUR TENT

- Ensure all five of your quick release valves on the driver's side are closed.
- Open the control panel door and if not already connected, insert and turn the red turn-key to power-on your vehicle.
- Press the Air Inflation button on your control panel to activate your compressor. - Wait for the tent to inflate to its full height before entering the camper. The compressor may still be running after the tent has extended to its full height; this is normal and is simply the compressor increasing the PSI to the required setting to make the Air Poles appropriately inflated. Once the correct air pressure is achieved the compressor will shut off automatically. There is no need to press the button again. **IMPORTANT:** Do not set up the interior of the camper until the tent has inflated to its full height. This can be identified by the visual 'popping-up' movement of the camper and by the straightening of the air poles.



OP2 SET-UP - CONT

STEP 5

SET-UP EXTERIOR

- Whilst the tent is inflating, level and stabilize the trailer. Fold down the stabilize leg by pulling out the blue handle.
- Use the included corner steady winder or 3/4" hex socket cordless drill/driver attachment, wind down each corner steady leg until it touches the ground.
- Depending on the terrain, you may need to adjust each corner to level the OPUS® to achieve a good level.
- While your tent is inflating you can use this time to set up your kitchen.

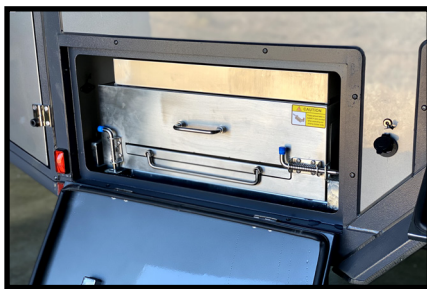
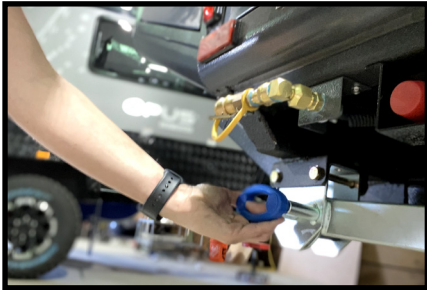

STEP 6

FOLD DOWN STEPS

- Use the triangle-end key to turn your door latches and open the door. Take care to hold the weight of the door as you fold it down to prevent it swinging down and causing injury. Adjust the height of the steps as required by unhooking the pins, sliding the legs out and replacing the pins.



STEP 7

SET-UP INTERIOR

- Turn the lights on via the control panel.
- The foot-well lights are controlled by the dimmable light switch on inside on the right of the door. Connect the interior ceiling lights into the 12v mini outlet.
- Set up your sofa. start with the center-back cushion, followed by the corner back cushions, then the side-back cushions.
- Fold out the legs of the table. Adjust the height of the table by pulling out the pins and extending the legs.

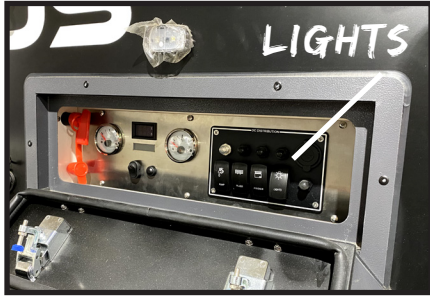

SET-UP TIPS:

- Ensure all five of your quick release valves are closed prior to inflating your camper.
- Ensure the center AIR beam is secured in place in the bed corner before inflating.
- Pull back the tension straps and tie them down to ensure the tent is sitting properly.
- While inflating, check that the OPUS® is stable and level prior to opening the two lids.
- IMPORTANT: Do not place or load anything on top of the tent whilst it is inflating.
- IMPORTANT: Ensure children or frail adults maintain a distance of 5ft from the air poles whilst it is inflating.
- Should you need to switch off the compressor for any reason whilst the tent is inflating, this should be done using the main power switch.
- Please note that the Air OPUS switch is not a 2-way on/off switch (meaning that pressing this twice will not turn the compressor off).



OP2 PACK-DOWN

STEP 1

PACK DOWN THE INTERIOR

- After stowing your personal items, close all both layers of all windows, making sure no water, dirt or debris is trapped between the layers.
- Ensure mattresses are secure using the straps provided
- Remove LED lights from the 12v mini sockets
- Tear down the sofa and fold away the table; stow the back cushions and table as shown in the below picture to optimize foot well storage space for other items and to ensure your table and cushions are stowed to prevent damage.

CUSHION PACK DOWN

1. Seat cushions can remain in place
2. Corner cushions stowed on the bottom, backs to the floor
3. Back cushions stowed in footwell



STEP 2

DEFLATE THE TENT

- Ensure that all users are outside of the tent and zip the front door closed.
- Open all 5 quick release valves, located externally on the offside of the camper on each of the vertical air poles. Make sure you release the valves using the middle ring as shown in the image. Allow the tent to deflate.



STEP 3

FOLD AWAY THE BED LID

- Lift the canvas off of the bed-end corners and fold the tent inside the seals of the trailer. Try to fold the tent into the main body of camper as much as possible; this will help to make closing the camper easier.
- Retract the steps and fold up and latch the door.
- Disconnect the bed-end supports and latches and fold over first the rear lid, then the front lid. Do not try to latch down the bed lid yet
- Walk around the camper to make sure that all of the tent is folded away within the seals.
- Push the bed lid down to allow air to escape. Twist open the triangle bolt latches to the maximum and push down on the bed lid so that the latches are over the hook. Do not try to close the latches until you have done this for each latch; the easiest and most efficient way to close the bed lids is to do it gradually.
- Push down on the bed lid enough to allow you to close the latches closest to the hinges first.



IMPORTANT! Do not use the latches as a lever to close the bed lid as this may cause damage to the camper and is not covered under warranty. Once you have closed the latches at the maximum extension of the triangle bolts, move around the trailer and tighten each latch. Each latch should be checked for a tight fit several times as tightening one can loosen others. Make sure that no tent is outside of the seal.

STEP 4

STOW YOUR KITCHEN

- Disconnect your water & gas quick connects from the kitchen as well as the 12v kitchen light.
- Ensure the water hoses are stowed in the drawer and that the drawers are closed on the catches properly.
- Stow the gas and waste water hose up through the aperture in the kitchen.
- Stow your kitchen support leg using the push-button retaining pin under the kitchen.
- Slide the kitchen back inside the camper and lock in place using both spring bolts. Close and Lock the kitchen storage door. **IMPORTANT!** Do not stow your kitchen whilst hot.

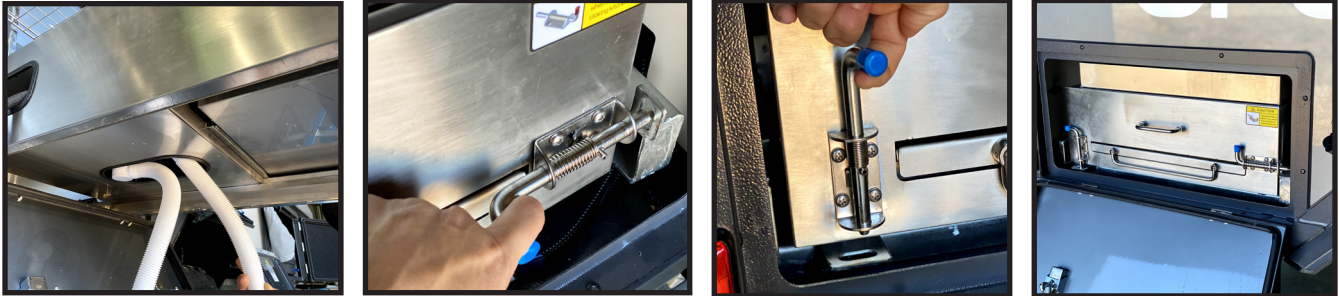

STEP 5

PREPARE FOR TRAVEL

- Fold over your cargo rack and secure with the latches. Twist down the triangle bolts to ensure a secure latch and secure the closed latch with the safety pin.
- Retract and fold up your stabilizer legs.
- Ensure all compartments are properly latched and locked.
- Connect to your tow vehicle making sure you lock the lock'n'roll securing pin in place using the locking pin and ensure the vehicle side of your hitch is properly secure and locked to your tow vehicle.
- Retract your tongue jack wheel and hold up. Connect your safety chains, breakaway cable and 7-pin to your vehicle and complete your pre-trip checks to make sure your connection is sound.



AIR TENT

AIR TENT DESIGN

Your OP2 AIR tent is made of 9 connected AIR beams in the main tent (and 9 beams in the annex if you choose that addition). The tent is inflated by the compressor that is mounted in the cabinet to the right of the door. The hose from the AIR compressor is threaded up through the cabinetry to the main AIR tent inlet valve. The compressor is activated by the button on the control panel, which also has a breaker switch should this be required. The air compressor is preset to the optimum pressure of 6.5psi and will automatically shut off when the pressure in the AIR tent reaches this pressure. Occasionally you may wish to adjust the psi to account for variations in outside air pressure (caused by altitude, temperature and extreme wind).

Our recommendation is to first check the suitability of the air poles at the preset pressure. If you then decide you require more or less pressure in the tubes the psi may be adjusted using the dial located on top of your compressor. Turn the dial to increase or decrease the pressure as desired, however you must not increase the pressure over 9psi and we recommend returning the pump back to 6.5 psi for normal camping.

Once your AIR tent is fully inflated and the compressor shuts off, please remove the hose from the valve and cap the valve. This will stop any air leaking out around the compressor hose. Failure to remove the hose and cap the valve may result in tent deflation.



Each Air Beam is connected to the beams next to it by an AIR transfer hose which has an isolation valve on each end where it connects to the AIR beam. Each AIR transfer hose has a spring inside it to protect it from kinks and bends that could damage the hose or prevent air passing between the beams. We recommend regular inspection of the AIR transfer hoses and isolation valves to ensure they are in good condition. You can find the AIR Transfer hoses by unzipping the semi-circle zippers in the roof of your tent. Should you need to close off the valve, the back section is turnable. There are markings on the valve to show which direction to turn for open and close. **IMPORTANT!** If you close off a valve, please remember to re-open it before trying to re-inflate your tent to ensure air can reach each AIR beam.

The AIR Beams are housed inside two protective layers; an inner thick protective layer and an outer layer built into the main tent. You should aim to keep the AIR beams enclosed inside the layers unless you suspect an issue with the air beam. Should you need to access the AIR beam, ensure that no part of the AIR beam is caught in the zip when you close it back up.



TROUBLESHOOTING - AIR TENT ISSUES

INFLATION ISSUES

- Make sure all of five quick release valves are properly closed.
- Make sure there are no extreme folds or kinks in the air beams (particularly the main air beam where the AIR compressor hose connects to) that could prevent air being transferred to the other air beams. The compressor will be able to overcome most folds but in some cases you may need to make a minor adjustment to the tent to allow air through more extreme folds that could be trapping air. If this happens, gently push on the middle air pole from the outside to help it straighten and allow the pole to inflate.
- Make sure all of the isolation valves are in the OPEN position otherwise AIR cannot pass between beams.
- Make sure your AIR Compressor hose is securely in the AIR tent inlet valve
- Should you experience issues with your compressor, you can use the included manual pump to inflate your tent. This will take around 5 minutes.

DEFLATION ISSUES

- We recommend opening each quick release valve and re-closing it in case you have cross-threaded the valve.
- Ensure you are removing the AIR compressor hose and capping the valve once you are inflated.
- If you suspect an AIR leak, use the isolation valves to close off each air beam so that you can identify which leak the beam is on. Take care not to over-tighten the isolation valves as this can damage the valve and in itself cause a leak. Remember to open up the valve again when you need to re-inflate your tent.

Should you identify a leak in your air beam or valve, please use the following map and contact OPUS HQ for a replacement beam. For field repairs, you can use the patch kit included with your OP2. We also recommend keeping the isolation valves closed until the air beam is replaced to help prevent tent collapse. For instructions on replacing the beam, please see the AIR beam replacement section of this user manual under Care & Maintenance.

AIR BEAM MAP - OP2 TENT

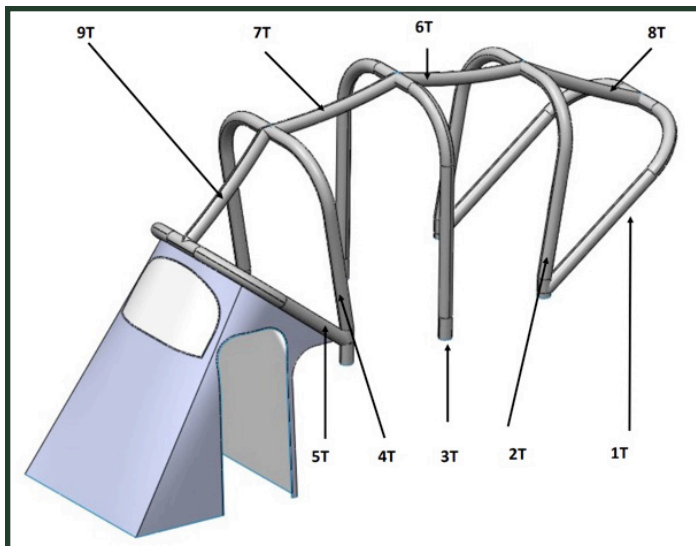

AIR BEAM MAP - OP2 ANNEX

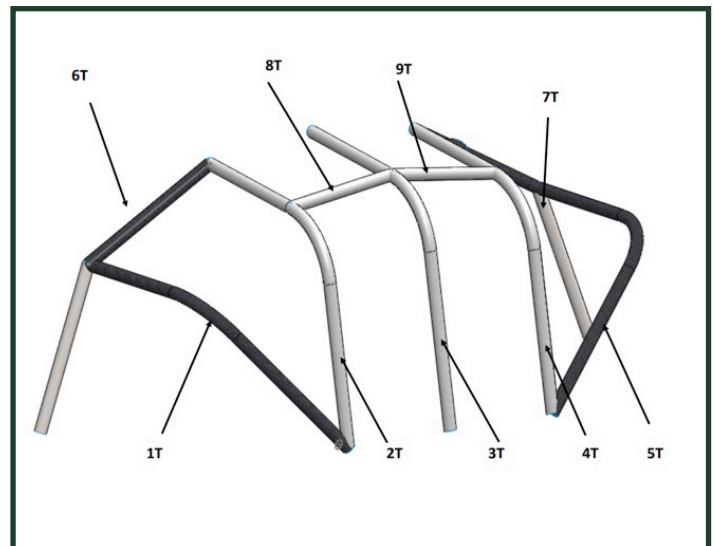

SLIDE-OUT KITCHEN

SETTING UP YOUR KITCHEN

Your OP2 kitchen is located on the door-side of the trailer in a slide-out compartment. The compartment is secured with lockable push-button latches. The kitchen slide-out is held in place with spring-bolt locking pins. To open up the kitchen, pull the spring bolts in and turn them so they catch and stay open then slide the kitchen out to its full extension. You can then access the kitchen side quick connects for your gas and water connections (please see the kitchen sink and Gas system sections of this user manual)



- **Kitchen Sink:** please see the water system section for information on setting up your kitchen sink with water.
- **Kitchen Stove:** please see the propane system section for information on setting up your kitchen stove with propane and use.
- **Slide-Out Surface:** The kitchen has an additional slide out surface tucked under the stove. We recommend placing only lighter items such as oven mitts or cooking utensils on this slide out
- **Stove Wind Protectors:** The stove has two wind protectors that fold out to each side of the stove and secure in place with pins that slot into a hole on the kitchen surface. See the Propane Gas System for details on lighting the stove.
- **Dish/ Spice Rack:** fold this up to vertical and set the rubber stand foot on the kitchen surface for stability.
- **LED Light:** Position the flexible light to the desired position. Plug the power cord for this light into the small 12v socket on the exterior of the OP2. Ensure that the *Lights* switch is turned on so that the socket is receiving power. Be sure to disconnect the light from the outlet BEFORE sliding away your kitchen.
- **Support Legs:** Folded underneath the slide out kitchen is a swing-down support leg. Push the button catch to release the leg. You can adjust the height of the leg as appropriate by loosening the wing nut pins to release the telescoping leg and then tightening them to hold it in place. To fold the leg away, retract the extendable leg fully and push the black end of the button catch to re-secure. There is also a secondary removable support leg pole which has a groove in the top that the underside of the kitchen fits into. This pole is also adjustable. We recommend using these support legs each time you set up the kitchen.



YOUR FRIDGE - ARB CLASSIC 63 QT

- We recommend reading the manufacturer's user manual that comes with your fridge in full to understand how this appliance works and to assist in troubleshooting should this be required. We have also compiled a few quick tips that are OPUS-specific:
- Your Fridge can be run on either 120v or 12v however we have designed the OP2 so that only 12v is supplied to the fridge compartment to enable the most energy efficient usage.
- The Fridge appliance is energy efficient and works well with minimum amperage draw. Please ensure that your fridge is set to 'low' or eco-mode to ensure you get the most efficient use and least impact on your 12v power consumption
- We recommend turning your fridge on and allowing it to come down to temperature 24 hrs before your trip and whilst connected to shore power as this is the time when your fridge will need to use the most energy
- You can leave the fridge turned on when you are traveling; simply ensure it is plugged in to the 12v socket in the storage compartment and that the fridge switch on the main control panel is turned on.
- Your fridge compartment is fitted with a fan-vent to help keep the temperature down in the compartment and so reduce the power consumption of the fridge. On hot days, you can also open the fridge compartment door but we recommend keeping the fridge inside the compartment when not in use to keep it shaded from the sun.

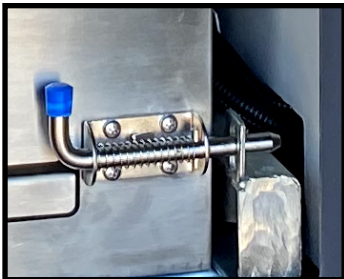
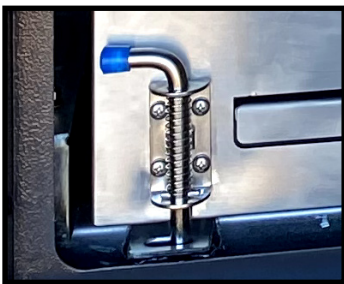
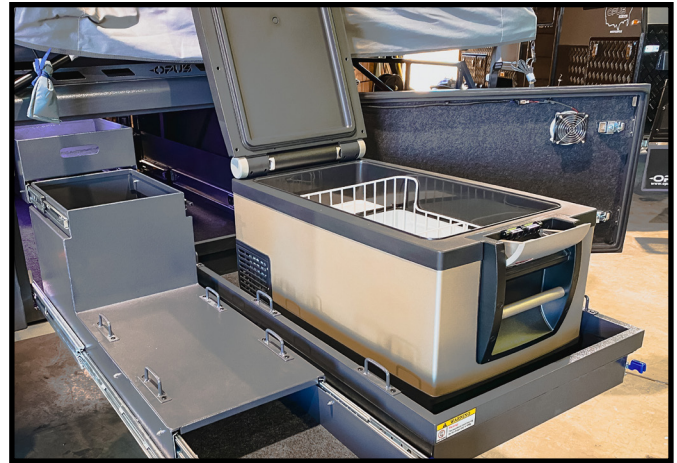

WARNINGS

WARNING! Ensure the spring-bolt locking pins are locked in place AND that the pushbutton locks on the door of the compartment are correctly closed and locked prior to travel. Failure to do so could result in serious injury and damage.

WARNING! Please make sure the spring-bolt locking pins are in the extended position at all times when the kitchen is set up so that the spring is not compressed. Failure to do so could result in serious injury. Take care to compress the locking pins again when closing the kitchen.

WARNING! Please ensure that all cords and hoses are disconnected and retracted prior to closing your kitchen to avoid damage.

IMPORTANT! Do not position the light over the stove. Always make sure that the power cord is removed from the outlet **BEFORE** sliding the kitchen away for storage to avoid damage to the light and the outlet.

GAS SYSTEM

SAFELY OPERATING YOUR GAS SYSTEM

The OPUS is fitted with a mount for one 20lb. Gas bottle. This bottle is to be connected to a gas regulator and turned off when the gas is not in use.

- **STEP 1.** To install a gas cylinder, place the gas bottle in the holder and use the provided clamp to hold the cylinder in place. Adjust the fit if necessary by turning the threaded triangle bolt. Ensure that you have the correct gas hose to connect the gas cylinder to the fixed gas regulator; your OP2 comes with a regulator-to-gas bottle pigtail hose which should be compatible with most US standard propane bottles.
- **STEP 2.** Once connected to the propane bottle, the gas tap/valve on the top of the gas bottle can now be opened.
- **STEP 3.** To connect the gas system on the kitchen; stowed under the sink there is a gas hose fitted to the stove that has a quick connect on the other end. Thread the gas hose through the aperture under the kitchen and connect to the gas quick connect on the side of the OP2. Turn on the gas tap on the gas quick connect on the side of the OP2 by turning 90° so that it is parallel with the fixture.



- **STEP 4.** To operate the gas stove; lift up the stainless steel lid, turn on one of the burners (push in, turn and hold to ignite). Keep pressing the button until the gas has had time to fill up the system and the burner will ignite. You may need to hold the button in for up to 10 seconds before ignition to overcome the accidental ignition safety precaution in-built in the hob. Do NOT lean across the burners to reach the stove controls. When the stove is not in use, please ensure the gas is turned off at the quick connect valve on the side of the OP2 and at the gas bottle.
- **STEP 5.** Ensure that the gas bottle valve is closed prior to packing up the OP2 for transit or storage, the quick connect valve on the side of the OP2 has been closed and that the gas hose has been disconnected from the side of the OPUS and carefully stowed inside the kitchen. Please make sure that the gas hose is fully inserted into the kitchen before sliding the kitchen into the storage compartment. Failure to do so can lead to the gas hose getting caught in the runners



which can lead to damage.

Do not use any other gas systems than those provided with the OP2. Always turn off the shut off valve IMMEDIATELY after use.

PROPANE (LP) / CARBON MONOXIDE (CO) DETECTOR

Your OP2 comes fitted with a propane (LP) / Carbon Monoxide (CO) detector installed is directly wired to the battery. Please read the user manual supplied for the detector to fully understand correct usage. If the Propane or Carbon Dioxide warning alarm sounds, evacuate the trailer immediately and, if safe to do so, close off and fully disconnect the propane tanks. Do not touch any electrical switches. Follow proper and safe steps to ventilate the trailer and await for the alarm to stop before returning to the trailer then disconnect the 120v shore power connection and turn off the 12volt power. If you suspect any chance of a propane leak, fully disconnect the propane tanks and make an appointment to have your OP2 serviced with your dealership. Do not use any other gas systems than those provided with the OP2. Always turn off the shut off valve IMMEDIATELY after use.

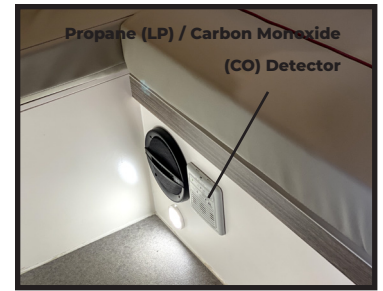

LP / CO DETECTOR: SHUT-OFF

When your OP2 is packed down the LP / CO detectors might go off from lack of air reaching the sensor. To override the beeping, you must inflate your tent and remove the fuse shown DO NOT FORGET to return the fuse to the correct operating position before using your trailer.



WARNINGS

Warning! Do not place propane cylinders inside the vehicle. Propane cylinders are equipped with safety devices that relieve excessive pressure by discharging propane to the atmosphere. Propane gas is highly flammable. Can lead to a fire or explosion and result in death or serious injury.

Danger! Do not use gas cooking appliances for comfort heating. Can lead to carbon monoxide poisoning, which can lead to death or serious injury.

Warning! Gas cooking appliances need fresh air for safe operation: before operating: open vents or windows slightly or turn on exhaust fan prior to using cooking appliances. Gas flames consume oxygen, which should be replaced to ensure proper combustion. Improper use can result in death or serious injury.

Warning! Do not fill propane container(s) to more than 80 percent of capacity. A properly filled container contains approximately 80 percent of its volume as liquid propane. Overfilling propane container(s) can result in uncontrolled propane flow, which could lead to a fire or explosion and result in death or serious injury.

Danger! If you smell propane:

1. Extinguish any open flames and all smoking materials.
2. Shut off the propane supply at the container valve(s) or propane supply connection.
3. Do not touch electrical switches.
4. Open doors and other ventilating openings.
5. Leave the area until the odor clears.
6. 6. Have propane system checked and leakage source corrected before using again.

Ignition of flammable vapors could lead to a fire or explosion and result in death or serious injury.

Warning! When using the outdoor cooking area, the vehicle must be level and stabilized. Do not violate manufacturers' instructions on required clearances for cooking appliances during use. Do not store cooking appliances until cool to the touch. Can lead to a fire and explosion and result in death or serious injury.

Danger! Gas fumes inside a camper trailer could result in unconsciousness, brain damage or even death. Follow safe operating procedure with gas at all times: ensure good ventilation at all times.

Danger! Check the instructions for correct fitment and safe use with the gas cylinder manufacturer/supplier.

Danger! Always ensure that the gas cylinder retaining straps are fitted whenever a gas cylinder is installed in the front locker compartment, even when the opus® is stationary.

Important! Please consult the opus team before completing any repair work on the gas system: the propane system installed includes a 2-stage regulator. The regulator must always be installed with the vent facing downwards.

The regulator is located on the front of the op14. Ensure that the vent for the regulator is not obstructed as blockages could result in excessive propane pressure causing fire or explosion

The propane system of the camper is designed for use with the supplied stove only; do not use any other gas appliance with it. The propane system is designed for use with propane only. Do not use other forms of gas.

PROPANE HEATER - TRUMA

MODEL INFO: TRUMA VARIOHEAT COMFORT FURNACE 16,000 BTU

Please read the TRUMA user manual for this appliance that is provided with your OP4 for full instructions and maintenance. Failure to follow the manufacturer's instructions can lead to damage, serious injury or death. Damage to the appliance or the OPUS as a result of failure to follow the manufacturer's guidelines for use and maintenance is not covered under warranty.

TO TURN THE FURNACE ON:

STEP 1: Turn on power to the trailer (red key)

STEP 2: Turn on the heater switch on the control panel

STEP 3: Open your propane. 1 turn of the tap for a full tank should be sufficient

STEP 4: Reset your thermostat to read TRUMA VarioHeat. You must reset the system each time you use it to avoid troubleshooting issues. Use the thermostat located outside the compartment your VarioHeat is installed.

A: Press large black knob in center of your thermostat to begin

B: Turn knob until wrench is blinking

C: Select the blinking wrench symbol by pushing the center of the knob

D: Press center knob again so the thermostat reads OFFSET

E: Turn center knob to the right until the thermostat reads RESET

F: Press center knob again so the thermostat reads PR SET

G: Press center knob again so the thermostat reads INIT..

H: Thermostat will begin to flash indicating it's properly communicating with your TRUMA system.

I: Once activated, your thermostat will return to the clock.

J: Press center knob and then select the blinking caravan icon.

K: Press center knob again until thermostat reads OFF

L: Adjust the thermostat to the desired heat by turning the center knob to the right and pressing in.

STEP 5: You will hear the fan start up first followed by the pilot clicking to ignite.

TO TURN THE FURNACE OFF:

STEP 1: Select caravan icon and push center knob so thermostat reads OFF

STEP 2: Turn the temperature all the way down to the left

STEP 3: Wait for the propane heater & fan to cycle off

STEP 4: When packing down the OPUS, turn the heater switch on the control panel off and turn the red key off and remove.

IMPORTANT! Ensure that nothing is stored inside the compartment that the propane furnace is installed in and that nothing is blocking the vent on either the interior or the exterior of the camper.

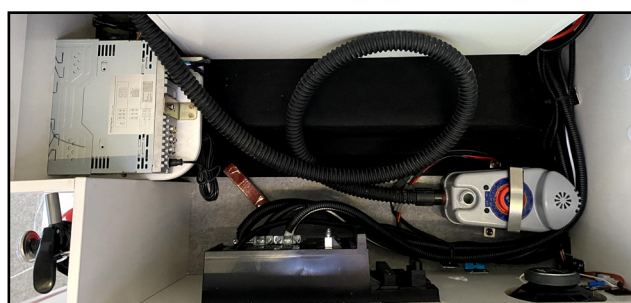

SETTING UP YOUR SHOWER TENT

The OP2 comes with a built-in shower tent with a connecting hot water shower. Using the Eccotemp and Seago water pump, the OP2 is able to pump both cold and hot water to the kitchen and shower. Following the below steps secure your shower tent to the main tent.



RUNNING HOT WATER TO YOUR SHOWER

In order to run hot water to your shower you must ensure the propane hose is properly connected to the yellow quick connect in the rear shower storage.

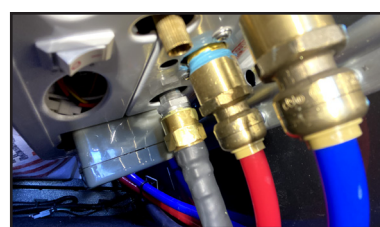

COMPONENTS:

1. Black Hose: Propane hose
2. Red hose: Hot water connect
3. Blue Hose: Water connect
4. Grey boxes: Under the Eccotemp you will find 2 batteries
5. Power switch: Under the Eccotemp in front of the connections, there is an on/off switch.

STEP 1

Connect the black propane hose to the yellow quick connect as shown.

STEP 2

Ensure the blue and red hoses are connected to the Eccotemp and running through to the water pump.

WATER SYSTEM

POTABLE WATER

The OP2 is fitted with 30 gallons of water in two potable water tanks (1x 20gl tank in the back, 1x 12gl tank in the front), one mounted in front of the axle and one behind. Each tank has its own lockable fill point located on the driver-side and identified by a blue water faucet icon. Your water tanks are each connected to the 12v water pump which can be switched on via the main control panel. The water pump is pressure operated, so once the main power switch is turned on at the control panel the pump will prime the system and as soon as you turn the tap on the water will flow. Once the tap is closed, the pump will turn off until the tap is turned back on. Please turn off your pump at the main control panel when the water system is not in use as it will continue to use battery power when it is turned on but not in use.

DO NOT run your water pump when the tanks are empty as this could cause the damage to the water pump and circuit.

You can use the water gauges on the main control panel to check the water levels in each tank. The tanks are gravity filled and included with your OP2 is a potable water fill hose which should be sanitized regularly. It is important to monitor the water levels in your tanks. When your water tanks or empty please turn off your water pump. Running your pump without water in the tank will cause your water pump to burn out. Please see the Troubleshooting section for tips if you are not able to draw from your potable water tanks.



WATER TANK SELECTOR LEVER (BLUE BALL VALVE)

You can use the water gauges on the main control panel to check the water levels in each tank. The tanks are gravity filled and included with your OP2 is a potable water fill hose which should also be sanitized regularly. It is important to monitor the water levels in your tanks. When your water tanks or empty please turn off your water pump. Running your pump without water in the tank will cause your water pump to burn out. Please see the Troubleshooting section for tips if you are not able to draw from your potable water tanks.

You can set your water pump to draw from EITHER the front OR the rear tank OR from both tanks. To do this, locate the selector lever located under your OP2, behind the driver-side wheel. You will see a blue lever at a junction of three water pipes. To select the FRONT tank, move the lever through 90° towards the F marking in the direction of the rear of the trailer. To select the REAR tank, move the lever towards the R marking in the direction of the front of the trailer. To select BOTH tanks move the lever to the center of the markings, so that the red arrows line up with the three water pipes. Please note if either of your water tanks is EMPTY please move the selector to the other tank and do not leave it on BOTH tanks.



THE ECCOTEMP

The Ecotemp Hot Water shower is installed directly to your water tank and propane supply in the rear the driver's side storage section of your OPUS®. Please note that this is a flow-through system meaning that your hot water is almost instantaneous from when you turn the shower on and no heat-up time is required.

IMPORTANT! Please read the supplied Ecotemp User Manual before using your Hot Water Shower for full instructions and safety notes. The below user guide is intended for setting up your Hot Water Shower with your OPUS camper and not as a full guide for the shower.

WARNING! The Hot Water Shower is capable of producing scalding water temperatures. Please take care to ensure your safety and those around you when in use. **WARNING!** The exhaust gas and top of the Hot Water Shower is HOT! Do NOT place hands or objects near the top of the heater. Always allow the Hot Water Shower to cool before dismantling and stowing. Always dismantle the Hot Water Shower before moving your OPUS® Camper.

IMPORTANT! Use only with propane. If you smell gas, turn off the gas valve at the tank immediately.

IMPORTANT! Always turn off the Hot Water Shower using the main power switch AND the propane flow at the Quick connect AND turn off the electric water pump at the control panel.



SUPPLYING WATER TO YOUR KITCHEN

Your OP2 is designed to directly feed potable water to the sink. To operate your kitchen faucet:

- Use the supplied blue water hose with male quick-connect fittings on each end.
- Connect one side to the middle quick connect on the side of the OPUS and the other side to the water quick connect fitting on the kitchen, accessible when the kitchen is fully extended.
- Turn on the front pump on your control panel
- Open the kitchen faucet.
- The kitchen has a drain hose attached to the sink drain. This is designed to drain to a waste water container or bucket.



PACKING DOWN YOUR OP2 WATER SYSTEM

Located on each potable water tank you will find a draining valve at the lowest point of the tank. When packing away the OP2 complete the following process to drain the system of any excess water.

- Switch off the pump on the main control panel
- Open the faucet & allow the excess water in the pipe to drain
- Close the faucet once all of the water has drained.
- Disconnect either side of the quick connect
- Ensure the sink is emptied and that the waste water drain hose is empty before folding it back into the kitchen.
- Your tank can be drained of water at a suitable location by removing the screw-in drain bolt on the bottom of each tank.

The rear tank also has a quick-access valve to on the side of the tank to allow quick drainage for better towing balance at the end of your trip in the case that your front tank is more empty than your rear tank. Please note that for long periods of storage we recommend using the low-point drain on the **BOTTOM** of the water tank to fully drain your tank of water.

Please refer to the steps in the care and maintenance section of this user manual for information on draining your tanks and preparing your tanks for storage. **IMPORTANT!** A small amount of water may be present from the connectors and waste hose so a cloth is useful to remove any excess water.



WARNINGS

WARNING! Only use potable water from a reliable source in these tanks. Do NOT store water in the tanks for more than two weeks.

WARNING! Sanitize, flush and drain the water tanks before using and a minimum of every 6 months.

WARNING! If you suspect there's an issue with the quality of your water, flush and drain your tanks.

IMPORTANT! Do NOT use bleach to sanitize the tanks, as they will cause corrosion to the stainless steel.

See the OPUS Care & Maintenance section of this manual for more information on sanitizing your water system. Failure to maintain your tank can result in death or serious injury.

ELECTRICAL SYSTEM

120V SHORE POWER - SAFE OPERATING PROCEDURES

The OPUS® comes fitted with a 120 volt power system. This 120 Volt power system complies with NFPA and NEC regulations.



- The main circuit breaker and panel is located inside the OPUS in the floor well. Always ensure you have clear access to the panel and it is not blocked at any time.
- The exterior shore power hookup is located on the driver's side on the main body of your OP2. With your OP2 we supply a 30ah shore power cable and yellow dogbone connection for both campsite and home outlet connection. The power cable connects directly to the side of your OPUS. The dogbone can be used to adapt the cable to plug in to your 3-pin socket at home.
- This shore power connection will provide your OPUS with 120v power to the two 3-pin sockets in your OPUS and provide power to your NOCO battery charger to charge your batteries.
- Take care to ensure proper maintenance of the power cord and pigtail accessory items. Always use a Listed and approved 30ah cable and adapter and a grounded power source. Never use an extension cord. **WARNING**
- **DANGER!** Due to potential danger in failing to heed this warning, the recreational vehicle manufacturer cannot be held responsible should damage, injury or death result from failure to connect the power cord to a properly grounded power source. **WARNING**

INTERNAL 12V POWER POINTS:

1. In the long bench storage compartment directly opposite the door.
2. This socket should have your Progressive Dynamics battery charger plugged in and is designed to supply the battery.
3. In the storage compartment to the right of the main door.
4. In the storage compartment behind the seating area next to the front bed.

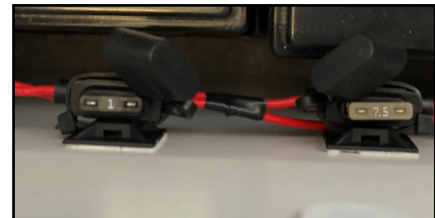
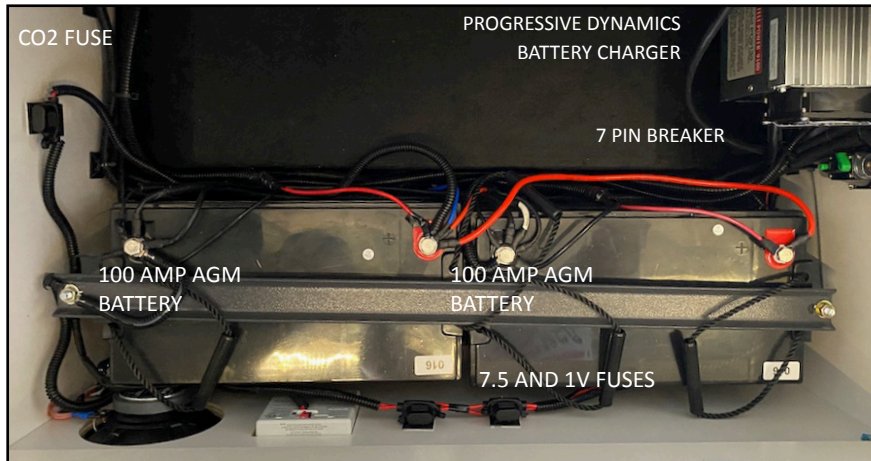

12V SAFE OPERATING PROCEDURES

The OP2 has two 100ah deep cycle marine batteries installed as well as a fully automatic battery charge controller. You will need to charge your batteries for at least 24hrs prior to each trip using a 120v shore power connection to ensure that they are fully charged. The main control panel has a battery volt-meter that will provide an indication of the charge level of your batteries. A fully charged battery bank will be indicated by a full battery symbol and the voltmeter reading around 13.7volts. If you are at a campsite with shore power then we recommend connecting for the duration of your stay to keep your batteries fully charged. If you are camping off-site without 120volt power then the length of time that your batteries will last will depend on how much 12volt energy you use, the 'health' or condition of your batteries and in some cases the ambient temperature. Your control panel will show you how much power you are using and how much remaining power is in your batteries to help you manage your power consumption.

Your 12v system is controlled by the main control panel which is located behind the exterior panel to the left of the door. On the panel you will find the main 12v switch (the big red key). There are separate switches for the Front water tank pump, Rear water tank pump, lights, 12v sockets, Fridge and Heater (Optional). To supply power to these features, use the red main power key and turn the 12v power on your unit and choose the associated switch.

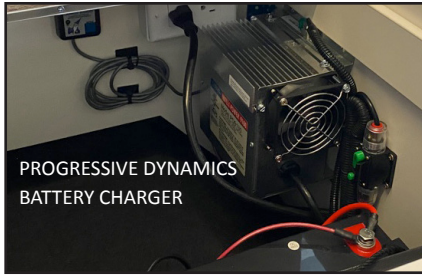

12V POWER - CONT

The OP2® has many 12v outlets that are a combination of standard 12v sockets, mini 12v sockets and USB sockets. There are also a range of 12v features included with the OPUS, all controlled by the main control panel, the locations of which are listed below. All switches have their own resettable breaker located above the switches.

OUTLETS

- The internal 12v sockets and external 12v socket will operate on 12v power from the leisure battery; heavy usage and power-hungry appliances will deplete the battery's charge quickly.
- Inside the OPUS® there are four 12v mini sockets. These are for the 12v LED light strips.
- There are two 12v outlets located a) by the main AIR hose inlet and b) inside the storage compartment behind the seating area next to the front bed. There is also a 12v/ USB outlet to the left of the door.
- On the exterior, there is one 12v outlets on the main control panel and one by the slide-out kitchen. There are also two additional 12v mini sockets and a standard 12v socket. The two mini sockets are designed to operate the 12v LED light on the kitchen and a small annex light.
- In the front tool box / fridge compartment here is a standard 12v socket intended for use with the fridge. In the same area there is a small switch that operates the fan located in the door (if fitted on this model)

LIGHTS

- In both exterior tool box/ fridge compartments there is an LED work light. This has an automatic on/off photosensor.
- Just inside the door by the 12v stereo there is a dimmer light switch that will control the interior footwell lights.
- There is also a rocker switch that controls the light for the exterior light mounted to the side of the OPUS by the kitchen.

OTHER 12V FEATURES

- There are two water tank gauges on the control panel which will display the water level when the 'water' button is pressed. For more information on your water tanks please see the water system section.
- The OP2 features a 12v stereo/ CD player with two speakers in the footwell
- The trailer lights and electric brakes are wired to a standard 7 pin trailer plug. The OPUS® is fitted with electric brakes with need an in-car electric brake controller installed to operate.
- The battery charger is fully automatic and will recharge the leisure battery if the OPUS® is connected to an electric hook-up. The battery will also charge whilst in transit if the tow vehicle has the 7-pin connection.

BATTERY TIPS

- The battery indicator on your control panel will show how much energy is left in your battery bank. It is important to note that it does NOT explicitly show how much useable power is left in your batteries.
- You have a 200 amp battery system. AGM batteries are able to reliably put out over 12.0v of power for 50% of their capacity. Most 12v appliances will require a 12volt output from the batteries to work. This means you 100 usable amp hours from a fully charge set of batteries. The indicator on your control panel will show you how much total energy you have in your entire battery bank. This means that when your indicator shows 50% you have used all of the usable power within your battery bank. If you continue to drain power from your batteries beyond this point can and will most likely cause damage to your battery bank.
- AGM battery lifespans are longer when they remain at full charge. Frequently discharging your batteries and leaving them empty will accelerate the degradation process of your batteries and reduce their lifespan. The NOCO Genius charger installed in your OP2 will control the amount of charge delivered to your batteries so that they do not over charge, therefore you can leave your OP2 plugged in at all times when at home.
- If you are not keeping your OP2 plugged in whilst at home we recommend that you disconnect your batteries to maintain good battery health. Please see the *care and maintenance section for more information on this topic.
- The CO/LP alarm is wired directly to the batteries. This means that turning the power to the OP2 off on the control panel will NOT shut power off to the CO Alarm. Please follow the winterization process for battery care to ensure you are fully disconnecting the batteries during long periods of storage.
- Always set your fridge to 'LOW' before heading out on your trip. This will use less power from your battery and allow you longer off-site camping.

OP2 OPTIONS / FEATURES

OPUS AIR CANOPY



ZAMP 140 WT SOLAR PANEL



RHINO ROOF RACK BARS



OP2 SHOWER TENT



BIKE RACK CARRIERS



ENDURO REMOTE TRAILER MOVER



OPUS AIR ANNEX



LED LIGHTS: ANNEX/CANOPY



DIMMABLE LED LIGHTS - TENT

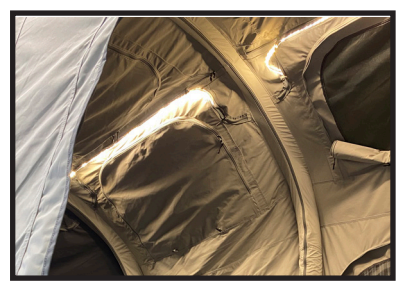

NEMESIS WHEEL LOCK



FOLD OVER CARGO CARRIER



ARK DUAL TONGUE JACK

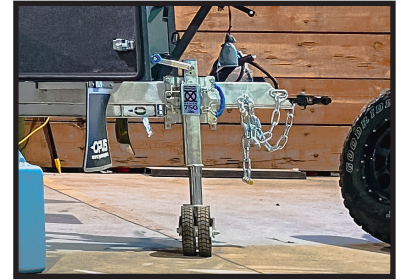

SHOP OPUS ACCESSORIES

Shop multiple options for cover, power, shade, security and gear to take you further off-grid. Use the corresponding QR Code to visit our website and purchase accessories through our parent company, Purple Line LLC.

LOUNGE SEATING MOVED TO CREATE ADDITIONAL BED

The seating area inside the OPUS® can be reconfigured to provide an additional bed.

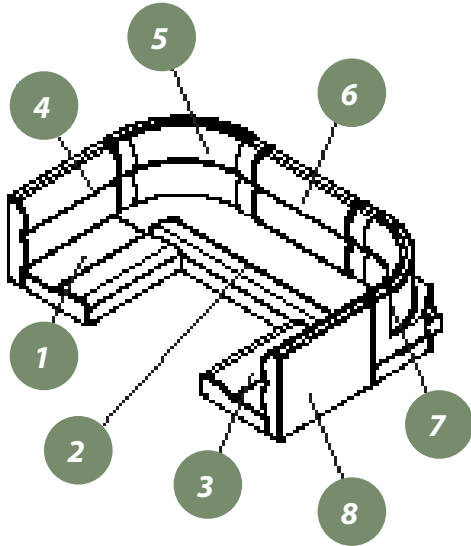

STEP 1

Firstly, position the table top in the position shown above to form the base section of the additional bed.

STEP 2

Arrange the cushions as shown above. Cushions 5, 6 & 7 are not required for the additional bed and can be removed.

STEP 3

The two bolster cushions fit into cushion number 2 - where cushion number 6 would usually sit. Then position cushion 4 to the far left, followed.

The furniture of the Camper with the inclusion of the table forms the base of the additional bed; the table is reinforced to provide adequate support for sleeping.



AIR CANOPY SET-UP

SETTING-UP THE OPUS AIR CANOPY

STEP 1

Locate the canopy air transfer valve inside your OPUS. This is the black valve located on your main air beam in the camper on the door-side, just above the window.

STEP 2

Install the Cross Filling Tube... by unscrewing the top of the black valve, pushing the gray tube on to the valve and then threading the top of the black valve over the tube and twisting it on. Thread the end of the Cross Filling Tube through the silver loop hole in the OPUS side wall.

STEP 3

Open the air transfer valve – please note that this will cause your tent to deflate. You can also open the quick release valves to deflate faster. You will need to do this to attain easy access to the zip line attachment on the front face of your tent.



STEP 4

Open up AIR canopy as shown and identify the zip & Velcro line which is how you will attach the canopy to your main tent and layout your canopy with the two front leg beams furthest from the camper.



STEP 5

Zip - Our recommendation is to then stand between the OPUS and the canopy and start zipping at the door side, walking backwards between the OPUS and the canopy as you close the zip. This will assist in locating both the Cross Filling Tube that you installed on the main OPUS tent as well as the receiving valve on the canopy-side about half-way along the zip line. The receiving valve is located on the central air pole of your canopy..

STEP 6

Once located, connect the Cross Filling Tube to the receiving valve on the side of the canopy. Take care to ensure that the spring is inside the grey tube to help protect the hose from getting kinked. Install the tube to the receiving valve in the same way as in step (2) except you will need to thread the top of the valve on to the Cross Filling Tube before you push the tube on to the valve. Twist the top of the valve on, to secure the tube in place.

STEP 7

Open the valve on the canopy-side. Finish zipping the canopy to the side of the OPUS and fold the Velcro flap over the zip.



STEP 8

Ensure both quick-release valves are closed on the canopy legs and all 5 on your OPUS main tent then press the AIR compressor button on the control panel and wait for the canopy to inflate.

STEP 9

Keep an eye out for obstructions and when the canopy is starting to form, feel free to help guide the air beams to assist an easy flow of air through them and form final canopy structure.

STEP 10

Once your canopy has inflated, you may find that the position of the AIR poles needs adjusting so that the canopy is fully tensioned. There are black straps between the beams on the main tent section, which will help to ensure the optimal placement of the beams. You can then peg the corners and guide ropes of the AIR canopy to the ground to secure your position.



DON'T FORGET...

CLOSE AIR VALVES



OPEN TRANSFER VALVE

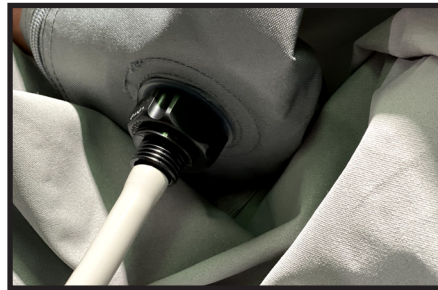

VELCRO CENTER BEAM



AIR ANNEX SET-UP

ANNEX COMPONENTS

1 x AIR OPUS Annex 2 x AIR Annex doors
1 x Cross filling tube 1 x AIR Annex Ground Sheet
2 x AIR Annex side walls 1 x Patch kit

STEP 1

Locate the Annex air transfer valve inside your OPUS. This is the black valve located on your main air beam in the camper on the door-side, just above the window.

STEP 2

Install the Cross Filling Tube by unscrewing the top of the black valve, pushing the grey tube on to the valve and then threading the top of the black valve over the tube and twisting it on. Thread the end of the Cross Filling Tube through the silver loop hole in the OPUS side wall.

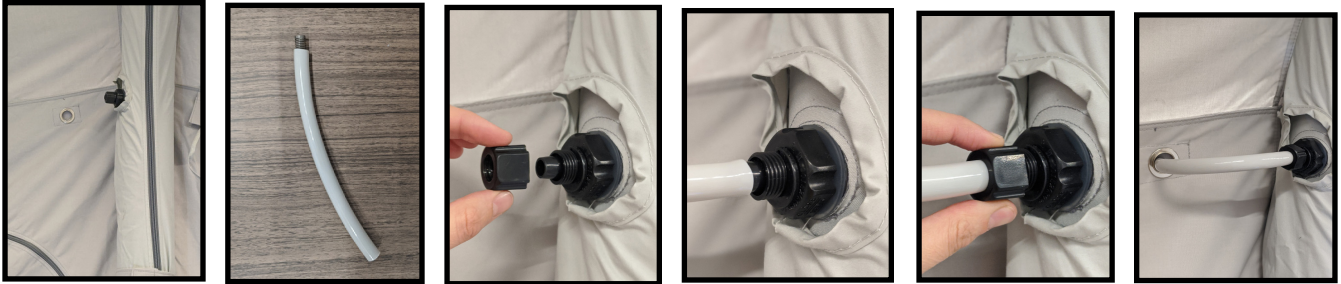

STEP 3

Open the air transfer valve – please note that this will cause your tent to deflate. You can also open the quick release valves to deflate faster. You will need to do this to attain easy access to the zip line attachment on the front face of your tent

STEP 4

Open up the main section of your annex. Identify the zip & Velcro line which is how you will attach the annex to your main tent and layout lay out your annex with the two front door sections furthest from the camper.



STEP 5

Our recommendation is to then stand between the OPUS and the annex and start zipping at the door side, walking backwards between the OPUS and the annex as you close the zip. This will assist in locating both the Cross Filling Tube that you installed on the main OPUS tent as well as the receiving valve on the annex-side about half-way along the zip line. The receiving valve is located on the central air pole of your annex.

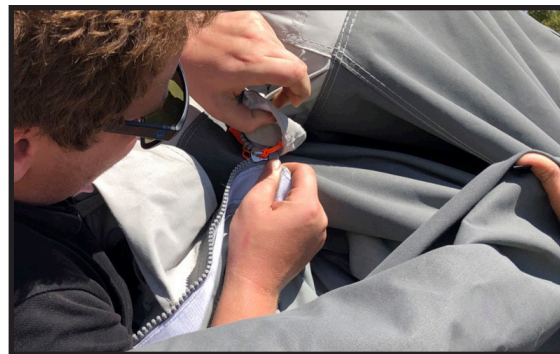

STEP 6

Once located, connect the Cross Filling Tube to the receiving valve on the side of the annex. Take care to ensure that the spring is inside the grey tube to help protect the hose from getting kinked. Install the tube to the receiving valve in the same way as in step (2) except you will need to thread the top of the valve on to the Cross Filling Tube before you push the tube on to the valve. Twist the top of the valve on, to secure the tube in place.

STEP 7

Open the valve on the annex-side. Finish zipping the annex to the side of the OPUS and fold the Velcro flap over the zip.

STEP 8

Ensure all 7 quick-release valves are closed on the annex and all 5 on your OPUS main tent then press the AIR compressor button on the control panel and wait for the annex to inflate.

STEP 9

Keep an eye out for obstructions and when the annex is starting to form, feel free to help guide the air beams to assist in easy flow of air through them and form final annex structure.



STEP 10

Once your annex has inflated, you may find that the position of the AIR poles needs adjusting so that the annex is fully tensioned. There are black straps between the floor-ends of the beams on the main tent section, which will help to ensure the optimal placement of the beams. You can then peg the corners and guide ropes of the AIR annex to the ground to secure your position.

STEP 11

Lay your optional ground sheet and attach this to the main tent using the zippers provided. There are zip-open sections of your ground sheet to allow the kitchen and fridge to slide out. You can also then zip on your side walls. Attach velcro seals between canopy and annex.

TO ATTACH THE WALL SKIRT

With your OPUS® annex fully inflated, you're ready to assemble the annex, and the first step is to attach the wall skirt:

STEP 1 - Position the OPUS® wall skirt along the entry side wall of your OPUS® Camper.

STEP 2 - Attach the skirt with the Velcro strips and zips around the edges.

STEP 3 - Peg the skirt to the ground with the five D-rings along the bottom edge.

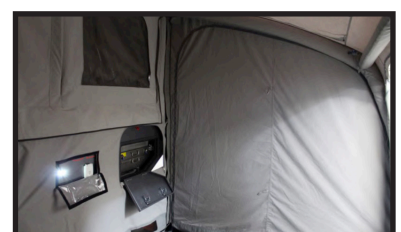
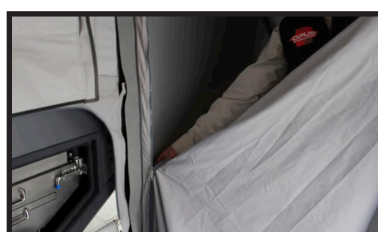
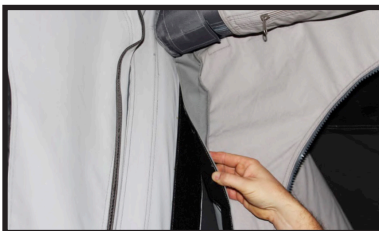

AIR Canopy & Annex Set-Up Tips:

- AIR OPUS® TIP: You may find that the AIR canopy is easier to shape with the side walls and front doors zipped closed, as this helps to create more structure to prevent the annex poles from distorting by over-extension when inflating.
- AIR OPUS® TIP: If your canopy takes longer than usual to inflate check that your quick-release valves are all fully closed and that none of the AIR poles are pinched, preventing AIR moving through. If this happens, you can easily move the air pole to allow AIR flow through and allow the pole to inflate.

CARE AND MAINTENANCE

NEW TRAILER MAINTENANCE

TRAILER BRAKES

Your electric drum brakes require a break-in period to achieve full and proper performance. This applies when you first receive your new OP2 then after new parts are installed as part of your maintenance schedule. Your OP2 brakes should be adjusted after the first 200 miles then every 3000 miles after that. We highly recommend that all brake adjustments, maintenance and ser-ving is carried out by a qualified technician at your OPUS dealership.

CAUTION! You may need to adjust your brakes more frequently dependent on variations in cargo weights.

SUSPENSION, WHEEL & HITCH BOLTS

After your first 50 miles then 500 miles after that please check the suspension bolts, wheel nuts and hitch bolts to ensure that they have maintained their tightness.

STEP 1: This should be completed with a torque wrench to 100 ft lbs.

STEP 2: When tightening wheel nut lugs, please tighten bolts in astar-patten order as indicated in the diagram.

STEP 3: After that, check your bolts every 2000 miles and always before an extended trip.

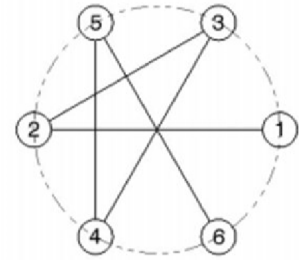

6 LUG BOLT
PATTERN

POTABLE WATER TANK

Please ensure you sanitize, flush and drain the water tanks before first use. Please refer to the water tank maintenance section for more information on this topic.

FIRE & LIFE SAFETY DEVICES

Your OP2 is fitted with a number of fire and life safety devices and comes with manuals and instructions for operating each device. These include:

1. PROPANE GAS & CARBON MONOXIDE ALARM—Locate in the footwell directly opposite the main door
2. SMOKE ALARM—located on the wall just inside the door to the right
3. FIRE EXTINGUISHER—located inside and to the right of the door.
4. EMERGENCY EXITS - Are shown on the below floorplan. They are 1) The main OPUS door; 2) Out of the front bed-end tent by zipping open the inner-tent window and then opening the zip along the the BOTTOM of the main tent (see image); 3) Out of the rear bed using the same method as in 2)

 **WARNING!** Please read and familiarize yourselves with the proper usage and maintenance of these features before using your trailer as outlined in their respective manuals.

 **WARNING!** It is possible that the alarms may sound when using products that give off vapors such as cleaning fluid, aerosols, adhesives etc. or if the sensor is covered by objects.

 **WARNING!** Failure to regularly test and properly maintain these devices may lead to serious injury or death.

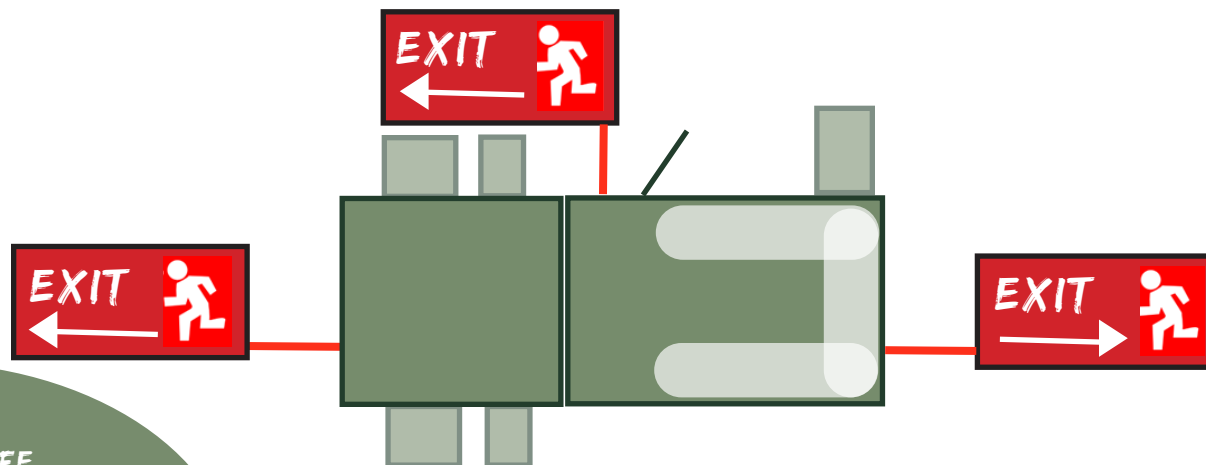

CARING FOR YOUR CANVAS

The tent and annex of your OPUS® are made from poly-cotton, a canvas type material. This has many benefits as it is breathable and results in a cooler interior in warm/ hot weather and a warmer interior when in use in cooler weather conditions. In order for the OPUS® to give you years of camping pleasure, the tent section needs to be cared for and MUST NOT be left wet/damp when packed away. It is, of course unavoidable at times that you will have to pack down your OPUS® when the canvas is wet. It is very important that the OPUS® is opened up to dry off as soon as possible and should be done within 24 hours.

- Except for the supplied gas hob, do not use a gas appliance or open flame inside the OPUS® and do not subject the tent to fire.
- Maintain adequate ventilation in the camper at all times, especially when sleeping.
- Allow condensation to clear and dry before packing/storing the camper.
- Regularly check the seams of the tent and if required apply some seam sealer such as Kampa Seam Sealer or suitable alternative. Follow the product instructions and allow to fully dry before packing.
- Regularly check the Velcro straps and seams, along with the clips on the inner tents.
- Never force the zips of the tent to open or close; inspect for any issues and rectify as necessary.
- Ensure the zips are used and cared for properly, if needed a zip lubricant can be used to allow for smooth operation.
- Regularly inspect the tent for holes, rips/tears and damages and have a suitable tent repair kit for use in emergencies.
- Take care when setting up and packing down the camper to ensure the tent, and the annex beading is not caught or snagged, should this occur retrace the steps and retry making sure the issue is rectified.

Should a rip/tear occur assess the damage before taking action. If unsure contact us on 925 215 7315 for advice. Small rips/tears can be repaired using the appropriate repair kit and procedure and may not require a professional or return to us for repair; should the damage be significant or exceed your capacity, please contact us.

- Clean the tent with warm water and a soft sponge (without a scourer), this may require complete set up of the camper (fully tensioning the tent) depending on the location/severity of the stain; allow the tent to completely dry before packing.
- Do not use washing up liquid, detergent or anything stronger as this could adversely affect the tent or result in some damage.
- The tent is NOT machine washable.
- AVOID sharp objects near the tent canvas; sharp/pointed objects and poles should be stored on the floor away from the tent to avoid damage.
- When the camper is packed, ensure nothing is sticking out and a proper seal is achieved around the periphery and the center (seal to seal contact).
- AVOID strain on the inner tents by loosening the attachment straps when necessary

WEATHERING

Your Air OPUS® tent has been manufactured using a polyester/cotton fabric. Before a polyester/ cotton canvas is used for the first time, it is important that the tent is weathered. Inflate the Air tent following the inflation instructions when rain is expected. When the cotton becomes wet for the first time, the weave of the cotton will close. There is no predetermined time for weathering so please do not be surprised if there is leakage through the canvas and seams the first few times it rains.

- Your OPUS® Air tent is made from the best available materials. On first examination, you may find some slight variances in color, thick threads, pigment stains and changes due to the weather and the environment. These are all normal and will not affect the continuing performance of the product and are not faults or errors.
- When your Air OPUS® is not inflated, the window material may pick up some impressions from zips, etc., this is quite normal and some of these impressions will disappear over time but some may remain. This is not a fault.
- Please ensure your Air Tent is only packed away when completely dry. A wet/damp canvas will develop mildew/mold very quickly and damage your canvas.
 - The inside and outside of your tent can be cleaned but only with fresh clean water and a damp cloth. UNDER NO CIRCUMSTANCES MUST DETERGENTS OR CHEMICAL CLEANERS BE USED AS THESE WILL DAMAGE YOUR CANVAS.

CARE AND MAINTENANCE

You may also experience, depending on the weather and use, condensation. This should not be confused with leakage. To reduce the risks of condensation, please ensure your product is adequately ventilated. Please note that under certain conditions, all tents will suffer from internal condensation depending on atmospheric conditions, the weather, the amount of moisture in the air/ ground, evening and night time temperatures etc. Condensation can be quite severe causing a film of water on the inside of your tent (roof and sides) which may drip onto items in your tent and in severe conditions can leave puddles of water.

Zips should be treated with care, use two hands when closing and opening and do not step on them during set up or take down. Never force a zip. If a zip opening is tight it is more than likely because your tent is not aligned correctly. Candle wax may be used to help a zip run more smoothly.

Please remember that your air tent is a temporary structure made from natural fibers. Please note that in fiber products used in outdoor applications, product life may be lower because of attack from UV or acid rain. Discoloration of the fabric may be an early indication that your tent has been attacked. To limit damage by UV, where ever possible, please site your air tent in a shaded area avoiding direct sunlight. Please be aware that continuous exposure is a more serious problem than intermittent exposure, since UV attack is dependent on the extent and degree of exposure. Fabrics can be weakened by prolonged exposure to sunlight and use for extended periods in strong sunlight will soon cause deterioration. UV degradation is not covered under the air tent's warranty. The Warranty does not cover air tents used permanently or for display purposes.

WEATHERING OF SWOLLEN THREAD USED FOR SEWING

Your OPUS® Air tent has been manufactured using a special sewing thread which expands and swells to close the holes made when stitching the product. The thread swells and expands when wet. It may take a few times for the holes to completely close.

ACCESSING AND REPLACING AN AIR BEAM

If you suspect your AIR tent has a leak and you have tried 1) removing and capping the main AIR inlet valve and 2) opening and re-closing your AIR quick-release valves, we recommend closing off your isolation valves for each beam. These are located behind the quarter-circle zips in the roof of your air tent. Twist the rear ring towards the "closed" position as indicated on the valve. The Air beam with the leak can be identified by a softening or complete deflation of the beam or a hissing sound of air escaping.

If you are in the field and can locate the source of the leak, you may be able to use the patch kit provided to patch the leak as a short-term fix in the same way that you would patch a bicycle tire. When you return home, contact OPUS HQ or your dealership and use the AIR Beam map in this manual to order your replacement AIR beam. All AIR beams and valves are covered under warranty for two years.

In some cases, you may find that simply by closing the isolation valves your tent stops deflating; this is an indication that the issue is in the valve or transfer hose and air is escaping when the valve is open. You can make sure that the grey transfer hose is correctly seated on the valve by unscrewing the front part of the valve that holds the grey hose in place. Push the grey hose back over the valve and screw the front part of the valve back on. If this does not resolve the leak then it is likely that the valve will need replacing. As the isolation valves are integral to the AIR Beam, the whole beam will likely need replacing.

To inspect or replace an AIR Beam, follow the below instructions to disconnect from the main tent. Depending on which beam you are replacing and its location, you may find it easier to keep your isolation valves closed with your AIR tent inflated to replace the beam.

1. Ensure all LED lights are off & unplugged whilst replacing the AIR Beam and that 12v power is turned off and shore power is disconnected. Carefully locate the faulty beam and deflate it enough so that you can manipulate the beam. Depending on the location of the beam, this may cause the tent to collapse partially which can cause a trip hazard if you are working from inside the tent. We recommend having a second person help to hold the tent up and maintain access to the exits.
2. Unzip the beam from the outer layer protective layer and remove velcro straps.

3. Disconnect the faulty beam from the AIR transfer hoses connecting it to the rest of the tent. Make sure the isolation valves are in the closed position on both sides of the AIR transfer hose. Unscrew the front part of the isolation valve until you can slide it along the grey hose. Pull the grey hose off of the valve. It is not screwed or glued in place, just a tight fit. Take care not to damage or stretch the grey hose and do not use tools to pry it off.



4. If the air beam you are replacing is 1T through 5T then you will need to disconnect the exterior quick release valve. unscrew the valve including the larger retaining nut at the back of the valve. This will allow you to push the rubber part of the valve connected to the air beam through the main tent and disconnect it from the inner protective layer.
5. You should now be able to remove the faulty AIR beam inside the inner protective sheath. Please note that it may be held in place by velcro at the ends. You can now unzip this and remove it for inspection and patching or replacing.
6. Next, take your repaired or replacement AIR Beam and insert it back into the inner protective sheath. Take care to avoid damaging the exposed rubber beam and do not catch the beam in the zip. Make sure there are no twists in the air beam and that the valves properly fit through the apertures in the sheath.
7. Re-insert the beam into the main tent. If the beam is 1T through 5T you can start by feeding the quick release valve back through to the exterior of the tent and replace the retaining nut and valve.
8. Re-connect the AIR transfer hose on the main tent to the new beam. Push the grey transfer hose over the isolation valve on the new beam and screw the front part of the valve back in place on the valve. Please note that you may find this part on the isolation valve on your new AIR beam too - if so, please retain this as a spare.
9. If you are satisfied the replacement AIR beam has been inserted correctly and the tube is fully inserted into the valve, zip the new beam inside the outer protective layers attached to the tent and replace the velcro straps. Position the ends against the velcro on the other beams or the interior furniture as required.
10. Open your isolation valves on the new beam and on the connecting AIR beams. You should hear and see the new beam fill with air quickly. Depending on which beam you are replacing, you may need to open the rest of the isolation valves and press the AIR compressor button to fully inflate the tent.

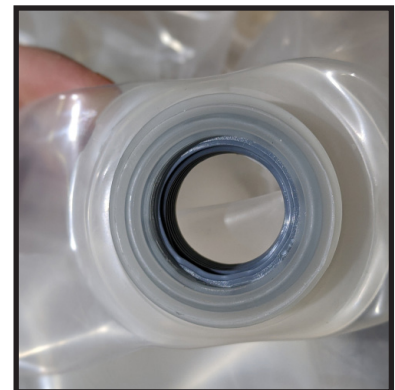

CARE AND MAINTENANCE

CUSTOMER'S RESPONSIBILITIES

In order to ensure you get the most out of your OP2 and that warranty claims may be processed in a swift and timely manner, we ask that our customers adhere to the following guidelines:

1. Regular and proper maintenance of your OP2, including but not limited to the steps outlined in this user manual. If you have maintenance or service questions not covered by this manual OR you notice something out of the ordinary with your camper please contact your dealership for more information This includes scheduled maintenance of your OP2 and addressing any issues as they arise and without delay
2. Get to know your OP2 well. By learning about your camper and its components you will get an enhanced user experience and avoid issues arising from mis-handling as well as become more likely to spot if something requires additional servicing
3. It is the responsibility of the OP2 owner to ensure all warranty work is completed by an approved OPUS dealership. Failure to do so may result in incomplete or refusal of warranty claim repair cost reimbursement.

Any modifications without written consent from OPUS Camper could result in loss of warranty coverage. Contact us or your dealer before completing any work.

EXTERNAL CARE FOR YOUR OP2

- Inspect the outside panels of your OPUS® including the roof (bed lids) for any damage, cracks or wear. Proper maintenance of seals is necessary to keep moisture from entering and causing severe damage such as rot, mold or mildew. If you find dry, cracked or weathered seals, reseal or replace as necessary. Check with your dealer for the type of caulking required for and correct methods of resealing or replacing.
- Inspect the sealant around the panels to verify that there is adequate bonding around the body panels and exterior features such as the front storage box/fridge cabinet. This is especially important after an impact/accident to the camper to ensure the integrity of the body's resistance to water ingress.
- Regularly check the seals (inner and perimeter) of the camper, to ensure there has been no damage. Ensure your OPUS® is packed properly on level ground to seal the camper and prevent water ingress. Failure to properly maintain your seals may be classed as neglect of maintenance and a decrease in coverage under your warranty
- Keep the body and the roof of the camper clean, it is best to clean any mud and dirt off the camper immediately after every journey to maintain its clean finish.
- Prolonged exposure to mud, dirt and salt may deteriorate the finish of the camper.
- Extended exposure to sunlight, air pollutants and excessive moisture can also negatively impact the finish of the camper. We recommend regular washing and protection during storage to maximize the lifespan of the finish.
- Inspect the condition of the frame, underbody, suspension and chassis regularly to keep it clean and address any damage that may lead to rust. This is particularly important when driving during winter when road salts are in use. Always clean down your trailer fully if you have driven in snow, mud or wet conditions and is road salt use is suspected.
- The body of the camper can be washed with soap and water using a soft sponge. Rinse the camper thoroughly after washing. A damp cloth may be preferred especially for small spots and dirt. Do not use a pressure washer as this can damage the finish. Avoid spraying water into vents and seals.
- Specialist products such as 'Waterless Wash and Shine' products may be used where/when adequate water is not readily available. Read and follow the instructions carefully and it is advisable to try any product to be used on the camper on a small inconspicuous spot to ensure/verify it is suitable before full use.
- Any form of damage or scratch to the paint work or finish of the camper on the body may be repaired or cleaned by using a suitable 'touch up' stick/paint. Contact OPUS® camper directly for further information.
- If your camper has been vinyl wrapped to a custom color care must be taken to prevent peeling of the wrap if a scratch or tear has occurred on the body panel.

INTERNAL CARE FOR YOUR OP2

- All cabinetry in the camper should be kept clean for maximum longevity; stains can be wiped off with a small cloth. A damp cloth may be all that is required to remove most stains.
- Wipe off any spills and water residue on the units as soon as they occur to prevent damage to them or other features of the camper such as the electrics.
- AVOID using abrasives including sponge scourers to clean the units as these may cause scratches and issues with the finish of the units.

- AVOID placing hot objects/containers (cups/saucepans etc.) on the units directly; use a suitable mat/cover to prevent marking the surfaces of the units.
- The cushions in your OPUS® camper are durable and simply require proper care and use.
- Clean off stains and dirt on the cushions as soon as they occur; this can easily be done using a damp cloth. Avoid soaking the cushions or prolonged exposure to water and ensure they are thoroughly dry before packing the camper.
- Vacuum the cushions (and the trailer) regularly or as often as needed depending on level of use. Pay extra attention to the trims as these may contain some dirt or undesirable items.
- AVOID stepping on the cushions with shoes or placing dirty items on them.
- Condensation is caused by warm, moist air coming into contact with cold surfaces. Moisture can be introduced into your OP2 from the shower, warm bodies breathing out water vapor and perspiring in an enclosed, sealed space. If condensation is left unaddressed for long periods it can lead to mold
- Be sure to check all water pipes, joints and fittings regularly for signs of leaks or seal failure. Water leaks can cause major damage inside your OP2. This also extends to all exterior joints and pipes. or damp which can be damaging to your health.

STORAGE

IMPORTANT! THE OPUS® CAMPER MUST NOT BE STORED WET/DAMP

- Pack down the trailer correctly and ensure nothing is out of place e.g. no canvas outside of the trailer, all windows and skylights are closed, all rubber gasket seals for storage compartments are intact and storage compartments are fully closed.
- Ensure the dust guards over the propane and water quick connects are cleaned periodically after every trip and at least once a year. Also make sure the dust guards are used when the hoses are not inserted.
- It is strongly advised that you use a storage cover for your OP2 if it is to be stored in an uncovered location. The OPUS storage cover provided with your camper is engineered for the OP2 specifically to ensure all features are protected. The storage cover is advised for an extended period of storage to keep your camper in pristine condition. Storage under a protective shelter is recommended.
- Clean off dirt and grime on the unit from travelling/terrain to keep your camper in good condition and maximize its longevity.
- Regular battery maintenance checks will prolong the life of your battery—see below section on maintaining your batteries during storage.
- Ensure the water tanks are emptied after use, and contain no liquids if being stored—see below section on water tank maintenance for further information.
- Store on a level surface, turn off all electrical switches and appliances, cover exterior appliance vents to prevent moisture and insects from entering during storage. Storage on unlevel ground can prevent proper drainage windows and seals leading to water ingress and potential mold or condensation issues.
- Check the interior of the camper periodically to be sure leaks have not developed or that condensation has not formed, causing damage to interior components. To reduce the possibility of condensation, air out the OP2 occasionally during storage.
- Keep the roof free from snow and ice. Check it periodically and after a heavy snowfall.

BATTERY MAINTENANCE DURING STORAGE

We have spec'd the Opus so you have the ability to leave your Opus plugged in without the need to remove the 30ah cable. We have done this for easy battery maintenance and care to protect your batteries from being completely depleted over long periods of storage which can cause your batteries to degrade faster. Our advice for simplicity of use would be to leave the camper plugged in, NOCO advertises that this is acceptable practice. Please follow these steps for proper battery care during periods of storage if you are NOT leaving your OP2 plugged into shore power during storage.

1. Completely charge the battery before storage
2. Store the battery in a cool, dry location. Heat is a battery killer. Do not forget to completely remove all loads from the battery (turn off your battery disconnect or remove the connection to your battery post).
3. Monitor the specific gravity or voltage. Once below 70% charge, give it a boost charge.
4. Completely recharge the battery before putting back in service.
5. Equalize the battery before putting back in service.

Following the above would mean that you need to disconnect the batteries entirely from your system, this would result in the Air Compressor not operating after winter storage; you would therefore need to manually inflate the tent for your first use.

POTABLE WATER MAINTENANCE

POTABLE WATER TANKS

Please ensure you sanitize, flush and drain the water tanks before first use and after any period of storage. To maintain the cleanliness of your potable water tanks please ensure you ONLY use water from a reliable source and that all water is flushed from your potable water tanks after each trip or every two weeks when in use. Do NOT store water in the tanks for more than two weeks. To drain your potable water system:

- Turn off the water pump
- On bottom of both potable water tanks is a drain plug. Open this plug to allow remaining water to gravity drain. Ensure water is collected and disposed of in a responsible way.
- Open your faucet & shower to allow any residual water to drain. Close the faucets again.
- Ensure the drain plug is closed again before re-fill the tanks.

We strongly recommend sanitizing your potable water tanks at least once every six months. If you suspect an issue with the quality of the water in your tanks or notice discoloration, odor or foul taste you should sanitize immediately. Always check your potable water source and use a fill hose listed for use with potable water. To sanitize your potable water system:

- Flush all water from system as detailed above
- Use a potable water sanitizing product such as Camco TastePURE Spring Fresh Water System Cleaner
- Do NOT use bleach to sanitize the tanks as they are stainless steel and it will cause corrosion
- Follow the steps as directed on your potable water sanitizing product to fill, sanitize and purge as required.

WINTERIZING YOUR POTABLE WATER SYSTEM

To avoid damage to your water system caused by cold weather or during long periods of storage, please follow these steps to winterize your water system:



WARNING! Do NOT use automotive antifreeze to winterize your potable water system as they are highly toxic and ingestion may leave to serious injury or death

- Drain the water from your potable water system following the above steps.
- Flush the water tanks with RV winterizing fluid; please follow the instructions on the label carefully to determine the correct dilution or amount of fluid to use.
- Using the water pump for both the front and rear tanks, run this winterizing fluid through the entire water system including the faucets and shower as well. This will lubricate and protect your water pump and fittings during storage.
- DO NOT use the water pump to run your tanks dry. Instead run the pump to get some of this fluid through the system.
- After winter follow the steps above to purge the winterizing solution from your system (you may need to flush with water several times) then sanitize your potable water system.

RETURNING TO THE ROAD

Ensure that your camper and accessories are fit for the road and you adhere to all local laws.

1. Check the wheels and tires and ensure they are in good condition with the bolts correctly torqued.
2. Check tire pressures once a month and before any extended trips
3. Check to ensure all bolts are tightened on the under carriage.
4. Check the lights and fittings and ensure they are functioning correctly.
5. Check the brakes are in good working order
6. The chassis/running gear and the gas installation of your OP2 camper should be checked on an annual basis by a qualified service center.
7. Purge your water tanks of winterizing fluid
8. Sanitize your potable water tank and add a treatment to the tanks as required.

GREASING & SERVICING

The electrical and propane systems will need to be checked over by an RV service technician. The lug nut torque requirements are 100ft lbs.



WARNING! Never use the levelling jacks to lift the trailer completely from the ground for any reason including servicing, repair work or tire changes. To do so would cause the trailer to become unstable and unsafe. Always use proper lifting equipment or have the work completed at an approved service location.

The servicing schedule may be affected by your usage amount and operating conditions. Discuss your intended use and servicing timetable with your dealership to find the optimum schedule for your OP2. It is always better to attend to or catch small problems early or before they occur rather than allowing problems to become larger or impact other systems or areas of your trailer. Failure to service your trailer in a timely manner may mean that issues may fall outside of or void your warranty due to failure to complete proper maintenance (neglect).

The servicing requirements are:

- Check the wheel bearings every year - ensure these are checked by a qualified service technician.
- Check the lug nuts every 2000 miles - this includes the spare tires nuts.
- Check the tire pressure every 2000 miles - the tire sticker on the interior of the door will supply the appropriate pressure.
- Have the dual coil suspension serviced every year; a dealership will complete the following services:
- Check and ensure the Zerk fittings on the suspension are in good condition and that these are removed and the suspension well oiled.
- Utilize a grease gun kit and some Moly-Grease .
- Check that the coil suspension is well greased (Moly-Grease suitable for suspension coils will also be acceptable here).
- Grease the hitch with some compound similar to Reese Heavy Duty Hitch Lubricant .
- Winterize the water tanks (see water system care & maintenance section).
- Look for signs of chipped paint around the body work. We can supply a cover paint kit to dress this.

CHANGING A TIRE

- Ensure you are on level ground
- Deploy your corner steadies
- ***Important*** DO NOT use your corner steadies to lift the trailer off the ground
- Use a jack on the suspension lift point to raise your trailer
- Change your wheel

Torque all wheel bolts to 100ft lbs. When tightening wheel nut lugs, please tighten bolts in a star-pattern order as indicated in the diagram to the right.

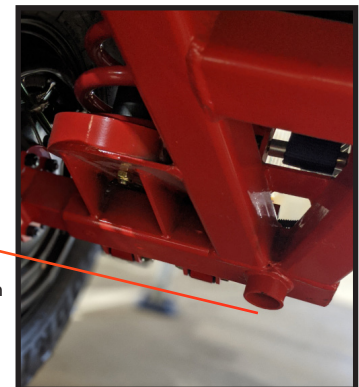

BATTERY INFORMATION

- Battery type: AGM.
- Best way to charge: Apply saturated charge to prevent sulfation; can remain on charge with correct float voltage.
- Charge methods: Constant voltage to 2.40-2.45V/cell, float at 2.25-2.30V/cell. Battery should stay cool -- no fast charge possible.
- Charge time: 14-16 hours.
- Discharge: Can endure high peak currents. Avoid full discharges. Charge after each use.
- Storage: Keep cells at >2.05V. Apply topping charge every 6 months to prevent sulfation.
- Disposal: Toxic. Do not dispose. Electrolyte corrosive. Profitable to recycle.
- How to prolong battery life:
 - Limit deep cycling.
 - Do not deep-cycle starter battery.
 - Apply fully saturation charge.
 - Avoid heat.
 - Transport : Flooded: Class 8 restrictions, provide "corrosive" label. Non-spillable: Class 8 exempt.

INSIDE YOUR OP2

LOCK'N'ROLL (VEHICLE SIDE)

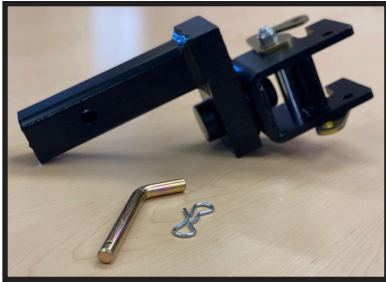

BED LID WINCH



SPARE PROPANE REGULATOR



OP2 SHOWER TENT



WHEEL CHOCKS



SHORE POWER EXTENTION



MANUAL AIR PUMP



MANUAL CRANK FOR STABILIZER



PATCH KIT FOR TENT



EXTRA KITCHEN SUPPORT LEG



DRILL BIT ADAPTER

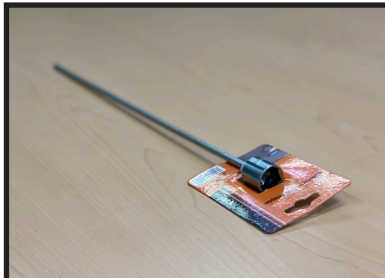

EXTERIOR LED LIGHT



SHOP OPUS ACCESSORIES

Shop multiple options for cover, power, shade, security and gear to take you further off-grid. Use the corresponding QR Code to visit our website and purchase accessories through our parent company, Purple Line LLC.

KITCHEN



ARB FRIDGE

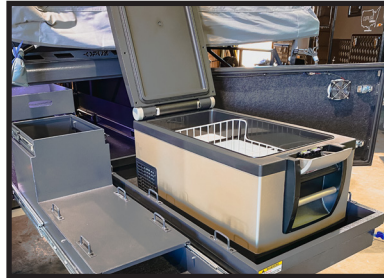

ANNEX



INTERIOR



SHOWER TENT



SHOWER TENT



TENT FRONT PULLED UP



AVAILABLE IN GREEN



FULLY ENCLOSED



SHOWER TENT



LIGHT UP AT NIGHT



BEACH READY



OP2 WARRANTY

INTRODUCTION

The following information relates to warranties offered by OPUS®. Please read all the information carefully, and should you have any questions relating to any aspect of this section, please contact OPUS®. By purchasing an item from OPUS®, you hereby agree to all terms and conditions of warranty as set out herein.

VALIDITY OF CLAIMS

- Warranties are only valid to the original purchaser of the item in question and are valid from the original date of purchase
- Warranties apply only to items sold as "new" and do not extend to any items sold via auction, or deemed to be "factory seconds", "ex-demonstration" or "damaged" unless specifically stated otherwise by OPUS® in (Please see further on this page for more information).
- Warranties are not transferable under any. Similarly, if an item is sold to a third party by the original purchaser, then all warranties become null and void, and the original purchaser shall make no claims or be eligible for any claims on behalf of the new owner.
- Warranties do not apply to products purchased from OPUS®, and then used in hire schemes or as rentals; or for commercial or business
- OPUS® does not cover damage due to unauthorized modifications, misuse, abuse, incorrect assembly, improper and irregular maintenance, or accident or
- Any work performed under an authorized warranty claim approved by OPUS® must be performed by OPUS®, or an authorized representative of OPUS® and only with the express written permission of OPUS®
- Any affiliates, representatives, associates, agents, suppliers, resellers or similar of OPUS® shall have no authority to authorize or deny warranty claims on behalf of OPUS®
- OPUS® shall not be liable, (in part or whole) for any warranties, either express or implied, made by agents or resellers on behalf of OPUS® without the knowledge or express written permission of OPUS®. Such unauthorized claims shall be the responsibility of the agent or reseller

CAMPER TRAILERS

Unless stated otherwise, trailers only are covered by a 24-month limited manufacturer's warranty from the original date of purchase. Our goods come with guarantees that cannot be excluded under Consumer Law. You are entitled to a replacement or refund for a major failure and for compensation for any other reasonably foreseeable loss or damage.

make a warranty claim to these manufacturers.

You are also entitled to have the goods repaired or replaced if the goods fail to be of acceptable quality and the failure does not amount to a major failure. OPUS® includes equipment and fittings, such as stoves, refrigerators, and sinks, which are separately warranted by their manufacturer and not covered by Opus®' Warranty. If necessary, OPUS® will help an owner

In addition to: OPUS® warranty, the consumer may also be covered by other rights and remedies of Consumer Law per state and/or federal regulations in relation to the goods and or services to which this warranty relates. Under no circumstances should OPUS® campers be exposed to water crossings at, or above, body floor level. The following items are not covered under Opus®' warranty: Impact or stone damage to body, chassis or running gear; soiling of fabrics and internal fitments from dust and other airborne substances; water damage due to water crossings; movement or damage caused by dislodgement of appliances and fittings resulting from hard impact or heavy landings or severely rutted roads or tracks; general damage arising from misuse; rust; wheels and tires; paint; travel covers and straps; general consumables (e.g. bearings, light bulbs etc); damage due to condensation; normal wear and tear; exposure to elements; wear and tear when the RV has been used for commercial, rental, business or permanent living purposes. The trailer is designed solely for its intended purpose of recreational camping and personal use. OPUS does not warranty trailers used for or commercial, rental, business or permanent living purposes, or any recreational vehicle not registered and regularly used in the contiguous 48 states of the United States.

TENTS

Tents are guaranteed to be in new merchantable condition at the time of purchase. A limited manufacturer's warranty period of 2 years applies to OPUS® canvas components, poles and fittings. General wear and tear excepted. Zips and mesh or screens are not covered. er from OPUS® any consequential or incidental damages.

PARTS & DESIGN CHANGES

The Purchaser shall deliver this camping trailer for warranty service within a reasonable time after discovery of the defect and in no event after expiration of the Warranty Period, which Warranty Period is twenty four (24) months.

All expenses incurred by the Purchaser in obtaining warranty service shall be borne by Purchaser. Warranty service shall, whenever possible, be scheduled with the selling dealer by an appointment in order to avoid possible delays.

PARTS & DESIGN CHANGES - CONT.

Purchaser can, if necessary, obtain a list of persons authorized to perform warranty service by contacting OPUS® at the below address. No action to enforce express or implied warranties shall be commenced without prior written notice to OPUS® at the address listed below of the alleged defect or nonconformity or the authorized repair facility's failed repair attempt and OPUS® , AT ITS DIRECT OPTION, SHALL HAVE A FINAL OPPORTUNITY TO REMEDY.

OPUS® reserves the right to change the parts and design of its recreational vehicle from time to time without notice and with no obligation to maintain spare parts or make corresponding changes in its products previously manufactured.

DISCLAIMER OF CONSEQUENTIAL & INCIDENTAL DAMAGES

The original consumer purchaser of this camping trailer and any person to whom this unit is transferred, and any person who is an intended or unintended user or beneficiary of this unit, shall not be entitled to recover from OPUS® any consequential or incidental damages.

EVENTS DISCHARGING OPUS FROM WARRANTY OBLIGATIONS

Misuse or neglect, including failure to provide reasonable and necessary maintenance, unauthorized alteration, accident, and improper loading, commercial use or leasing of the recreational vehicle, shall discharge OPUS® from any obligation under this Warranty.

FACTORY SECONDS, EX-DEMO & DAMAGED GOODS

From time to time, OPUS® may offer for sale items deemed to be "factory seconds", "ex-demonstration", or "damaged". Any items sold as "factory seconds", "ex-demonstration" or "damaged" items are sold on an "as is" basis. There are no warranties, refunds, credits, exchanges or similar associated with such items. In the sale of such items, OPUS® will attempt to provide all relevant information regarding the item, including faults, defects, or similar, however, there may be instances where minor defects or imperfections have been overlooked.

This is PURELY UNINTENTIONAL and in no way alters the nature of the sale. Due to the nature of such items, i.e being "ex-demonstration", "factory seconds" or "damaged", it is reasonable to expect that some imperfections or flaws may exist even where it is not initially apparent. By purchasing such an item, you agree to this statement in full and accept that there are no warranties.

OWNER ASSISTANCE

Your continued confidence and goodwill are important to us at OPUS® as is maintaining a good relationship with our dealers. OPUS® recognizes that there may be occasions when a warranty or service problem is not handled to your satisfaction. We encourage you to attempt to rectify the situation by discussing the situation with your local dealership management; if after this your problem is not resolved to your satisfaction we welcome you to contact OPUS® at the below address. We will provide our recommendations for an agreeable solution to the local dealership.

THIS WARRANTY GIVES YOU SPECIFIC LEGAL RIGHTS AND YOU MAY ALSO HAVE OTHER RIGHTS, WHICH VARY FROM STATE TO STATE.

LODGING A CLAIM

All warranty claims can be lodged by contacting your dealership.

If you have any further questions relating to warranties, or are unsure about any aspect of this section, then please contact us:

CONTACT

Phone: 925 215 7315

Email: info@opuscamper.us

Address: 1850 Loveridge Rd, Pittsburg, CA 94565

TROUBLESHOOTING

WATER TANKS - TROUBLESHOOTING

Issue: Water pump is running when all faucets & valves are closed

Troubleshoot: Leak in the system. Identify leaking fitting and attempt to tighten the fitting (usually hand-tight should be sufficient without the need for a wrench which could potentially over-tighten and damage the system. If still leaking, disconnect and check for debris or degrading within the fitting.

Issue: Water pump running but no water at faucets

Troubleshoot: No water in tanks? Check for faulty sensor that could be misleading you to think that there is water in the tanks. Possibly the sensor needs cleaning or replacing.

Check the tank selector valve is directed at the correct tank (or both tanks are chosen).

PROPANE SYSTEM - TROUBLESHOOTING

Issue: Stove top won't stay ignited

Troubleshoot: Press and hold the ignition/ dial for 10 seconds to overcome the safety thermocouple.

Consider the outside temperature; cold weather can cause the BTU of propane to drop. This can impact overall performance of the propane system. Keep your propane tanks full during cold weather and check other appliances that might also be using propane at the time.

HEADQUARTERS

OPUS Camper USA
1850 Loveridge Rd.
Pittsburg, CA
94565

CONTACT

925.215.7315
info@opuscamper.us

WARRANTY

Register your warranty online at:
<https://www.opuscamper.us/warranty-claims/>

ONLINE OWNER'S MANUAL

Download a digital copy of the OP2 Owner's Manual to have on hand at all
times:
<https://www.opuscamper.us/2-SLEEPER>

ONLINE OWNER'S GROUPS

Join the OPUS online community where you can ask other owner's for tips and advice and
share trips and memories with other OPUS owners.

OPUS OWNER'S ONLINE

www.opusowners.com

OPUS OWNER'S FACEBOOK GROUP

<https://www.facebook.com/groups/1486807838283406>

FACEBOOK

<https://www.facebook.com/OPUS.Folding.Camper.USA/>

INSTAGRAM

@opuscamperusa



BUILT BY OPUS CAMPER USA IN PITTSBURG, CA

1850 LOVERIDGE ROAD, PITTSBURG, CA 94565 | 1 (925) 215-7315 | INFO@OPUSCAMPER.US



2022 USER MANUAL

